

MULTIGRIP MGR-F FLANGE ADAPTOR

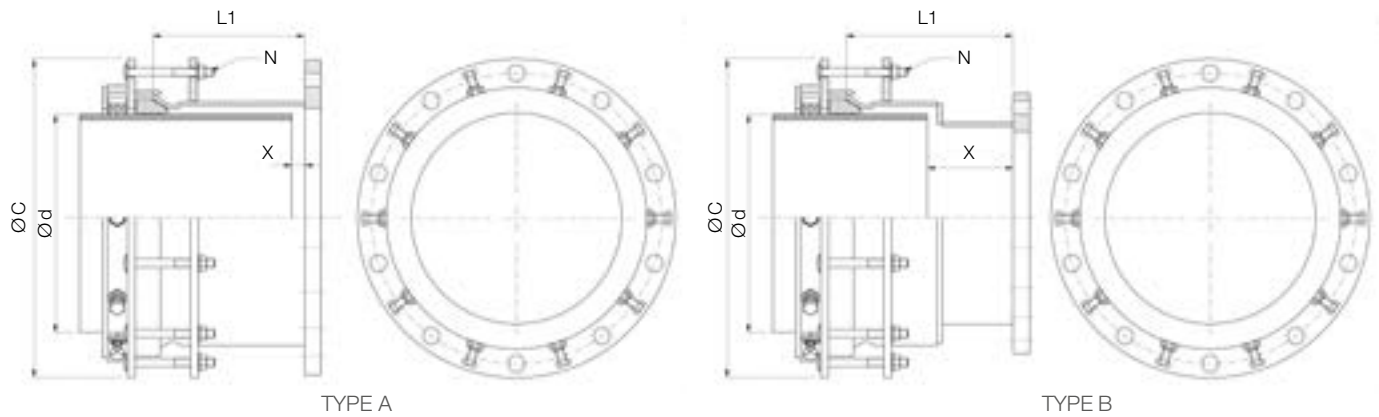

PN 16 RATED HYDRAULIC SEALING AND END RESTRAINT SYSTEM

Other sizes or ranges on request

DN	Ød		Flange DN	Flange PN	TYPE	L1	Max. External Dimension ØC	Compression Bolts	Gap X		Weight		
	Min.	Max.						Quantity N	Max.	Min.			
350	340	370	350	6-10-16	A	296	560	9	220	25	132		
	360	390		6-10-16			580				136		
400	385	415	400	6-10-16			600				150		
	415	445		6-10-16			640				157		
450	440	470	450	6-10-16			660	178					
	465	495		6-10-16			680	183					
500	490	520	500	6-10-16			720	208					
	515	545		6-10-16			740	213					
	545	575		6-10-16			B	326			788	14	250
600	595	625	600	6-10-16			A	808			15	220	25
	615	645		6-10-16	828	265							
700	695	725	700	6-10-16	908	278							
	720	750		6-10-16	933	291							
800	785	815	800	6-10-16	998	330							
	795	825		6-10-16	1008	332							
	825	855		6-10-16	1038	342							
900	885	915	900	6-10-16	1098	355							
	900	930		6-10-16	1113	375							
	930	960		6-10-16	1143	440							
1000	985	1015	1000	6-10-16	1198	490							
	1000	1030		6-10-16	1213	494							
	1030	1060		6-10-16	1243	510							
1200	1185	1215	1200	6-10-16	1398	-							
	1205	1235		6-10-16	1418	-							
	1240	1270		6-10-16	1453	-							
1400	1385	1415	1400	6-10-16	1598	-							
	1405	1435		6-10-16	1618	-							
	1445	1475		6-10-16	1658	30	-						

The data concerning the min. and max. gap is calculated on the minimum outside diameter of the product's range

This chart is for indicative purposes. Nova Siria srl can vary the indicated standards (tolerance range, dimensions and materials) according to specifications requested by Customers or to designing needs.

NOVA SIRIA end restraint fittings are suitable for the following pipes: steel, ci/DI, PE, pressure PVC.

All end restraint fittings installed on pe Or pressure PVC Pipes must be integrated with an internal reinforcing liner provided or approved by noVA SIRIA.