

Technical Documentation

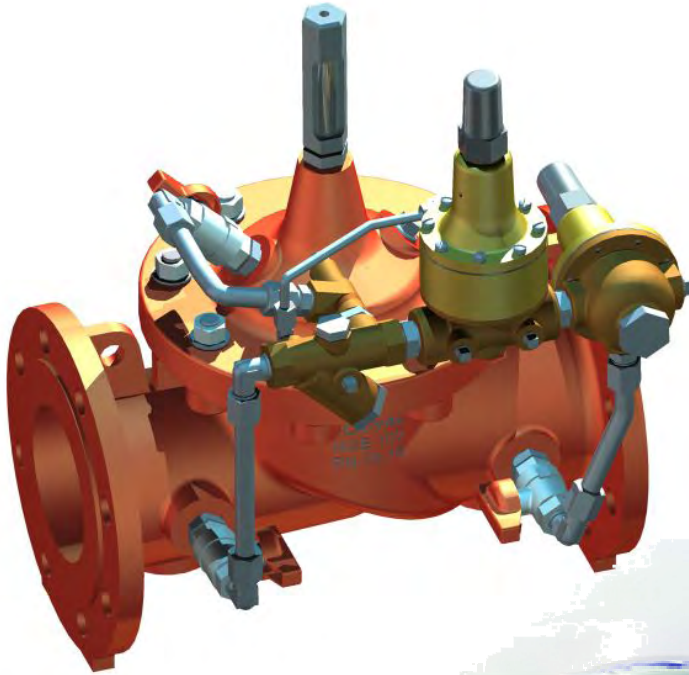

- Engineering Capabilities
- Industry Experience
- Certification & Approvals
- Typical Applications
- Global Operations
- Markets & Applications

► Table of Contents

- Main Function & Application
- Schematic Diagram
- Operating Data
- Main Valve Description
- Dimensions
- Installation & Maintenance
- Controls & Accessories
- Valve Specification Form



► Simple, Reliable and Accurate

- Completely Automatic Operation
- Easy Adjustment and Maintenance
- Quality Approved Materials
- World Wide Support

► CLA-VAL SERIES 90 Main Function

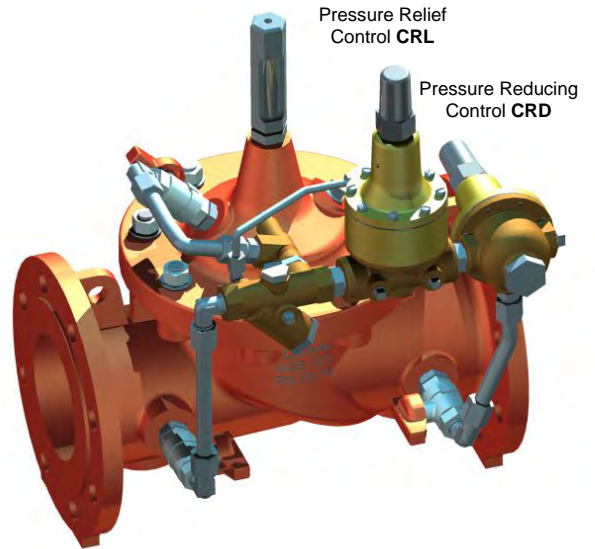
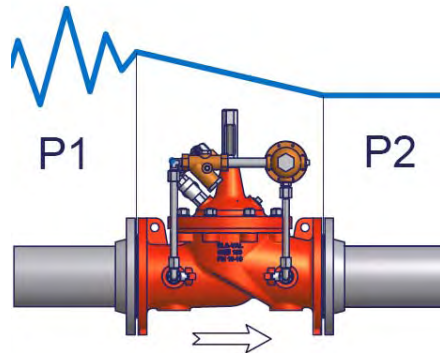

The CLA-VAL SERIES 90 reduces a higher inlet pressure to a constant downstream pressure (Pressure Reducing Control) regardless of changing flow rate and/or varying inlet pressure.

► CLA-VAL 92-01 Typical Application

The CLA-VAL 92-01 is designed to reduce a high pressure (P1) and to sustain a minimum upstream pressure. Reducing pressure for a downstream distribution network and sustaining a minimum upstream pressure in a high pressure main and/or for an upstream distribution network is a typical application.

Make your valve even Better!

LFS Option?	<u>Control</u> Low flows or night flows
KO Option?	<u>Extend</u> valve life with Anti-Cavitation trim
KG1 Option?	<u>Use</u> stem cleaning for harsh water
Maintenance?	<u>Check</u> on periodic maintenance
Environment?	<u>Adapt</u> to high temperatures or frost risk
Security?	<u>Add</u> hydraulic safety back-up to your valve
Protection?	<u>Remove</u> excessive system overpressures
Corrosion?	<u>Protect</u> your valve with upgraded materials

Not just Products but Solutions: contact CLA-VAL!

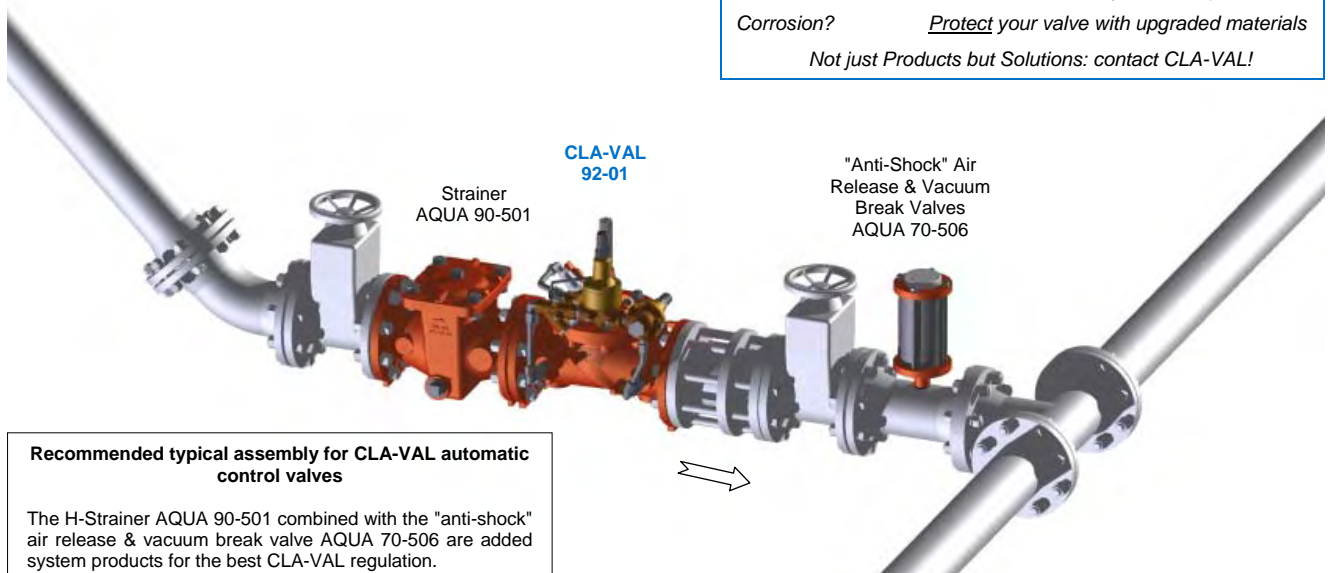

Recommended typical assembly for CLA-VAL automatic control valves

The H-Strainer AQUA 90-501 combined with the "anti-shock" air release & vacuum break valve AQUA 70-506 are added system products for the best CLA-VAL regulation.

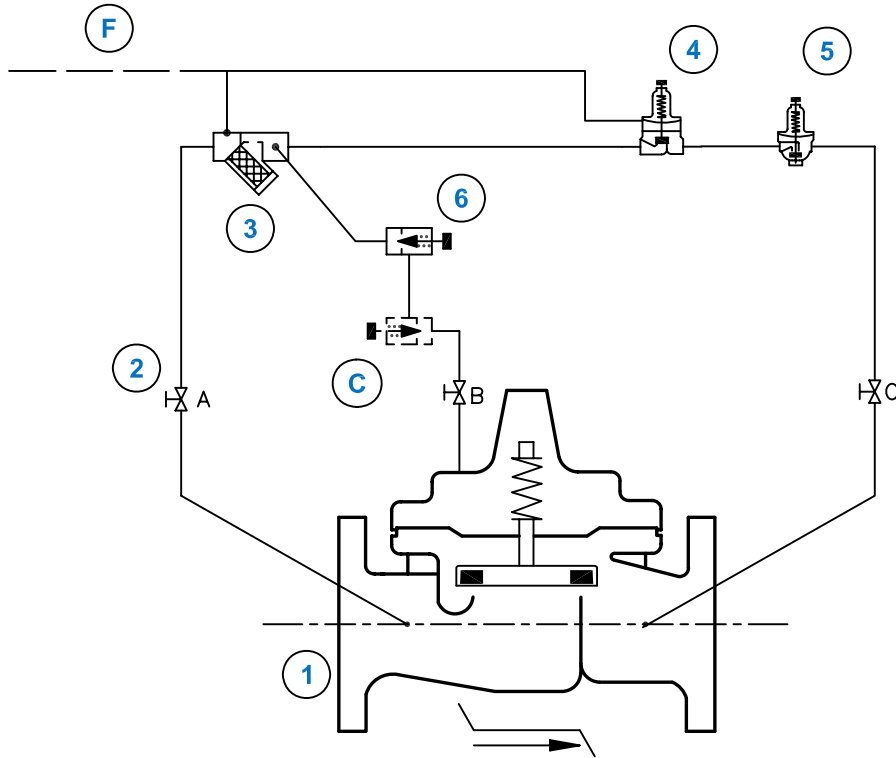

STANDARD EQUIPMENT

No	Description	Qty	Type
1	MAIN VALVE HYTROL AE/GE/NGE	1	100-01
2	ISOLATION BALL VALVE	3	RB-117
3	STRAINER WITH INCORPORATED ORIFICE	1	X44-A
4	PRESSURE RELIEF CONTROL	1	CRL
5	PRESSURE REDUCING CONTROL	1	CRD
6	ONE-WAY FLOW CONTROL	1	CV

OPTIONAL FEATURES

No	Description	Qty	Type
F	REMOTE SENSING	1	-
C	ONE-WAY FLOW CONTROL (CLOSING SPEED)	1	CV

NOTES

AE/GE : DN 32 - DN 400 / NGE : DN 50 - DN 600

OPTIONAL FEATURES : _____
NOT FURNISHED BY CLA-VAL : _____

▶ Operating data

1.1 ▶ PRESURE REDUCING FEATURE

Pressure reducing control (5) is a "normally open" control that senses main valve outlet pressure changes. An increase in outlet pressure tends to close control (5) and a decrease in outlet pressure tends to open control (5). This causes main valve cover pressure to vary and the main valve (1) to modulate (open and close) maintaining a relatively constant outlet pressure.

Pressure reducing control (5) adjustment: Turn the adjusting screw clockwise to increase the setting.

1.2 ▶ PRESSURE SUSTAINING FEATURE

Pressure relief control (4) is a "normally closed" control that senses main valve inlet pressure changes. Control (4) is open if inlet pressure is higher than the set point of control (4). This places pressure reducing control (5) in command of the main valve (1). If inlet pressure lowers to the set point of control (4), control (4) closes. This pressurizes the main valve cover and the main valve (1) closes, sustaining the desired minimum pressure at the main valve inlet.

Pressure relief control (4) adjustment: Turn the adjusting screw clockwise to increase the setting.

1.3 ▶ OPENING SPEED CONTROL

Flow control (6) regulates the opening speed of main valve (1).

Flow control (6) adjustment: Turn the adjusting screw clockwise to make the main valve open more slowly.

1.4 ▶ (E*) EUROPEAN STANDARDS

ITEM (2) - Isolation ball valve:

The isolation ball valves are used to isolate the pilot system from main line pressure. These isolation ball valves must be open during normal operation.

ITEM (3) - Y-Strainer with incorporated orifice:

The strainer is installed in the pilot supply line to protect the pilot system from foreign particles. The strainer screen must be cleaned periodically.

1.5 ▶ OPTIONAL FEATURES

Suffix (C) - Closing speed:

Flow control (C) regulates the closing speed of main valve (1).

Flow control (C) adjustment: Turn the adjusting screw clockwise to make the valve close more slowly.

Suffix (F) - Remote sensing:

Remote sensing is obtained from a point upstream of the main valve (1) inlet, by a pipe size Ø 12mm (not furnished by CLA-VAL Europe), which must not have any high points and so formation of air pockets and avoid any pulsation of control.

1.6 ▶ CHECK LIST FOR PROPER OPERATION

- System valves open upstream and downstream.
- Air removed from the main valve cover and pilot system at all high points.
- Isolation ball valves (2A), (2B) and (2C) open.
- Periodical cleaning of the filter screen (3).
- Remote control line properly connected [optional feature (F)].

▶ Simple, Reliable and Accurate

▶ CLA-VAL SERIES 100 Main Function

The CLA-VAL 100-01 HYTROL Valve is a hydraulically operated, diaphragm actuated, globe or angle pattern valve.

It consists of three major components: body, diaphragm assembly and cover. The diaphragm assembly is the only moving part, guided top and bottom by a precision machined stem. The disc retainer and rubber disc form a drip-tight seal with the renewable seat when pressure is applied above the diaphragm (cover chamber).

The CLA-VAL 100-01 is the basic valve used in nearly in all CLA-VAL Automatic Control Valves.

There are 3 HYTROL body types:

NGE: New Globe Execution
 GE: Globe Execution
 AE: Angle Execution

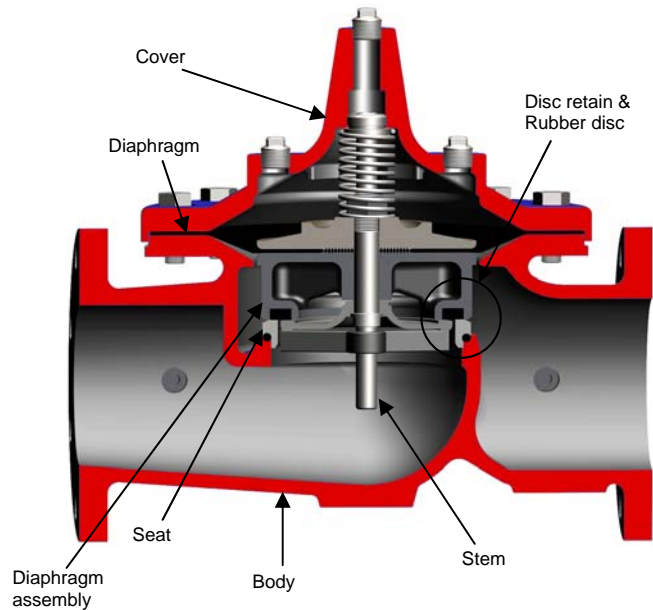

▶ CLA-VAL 100-01 Principle of Operation

On/Off Control

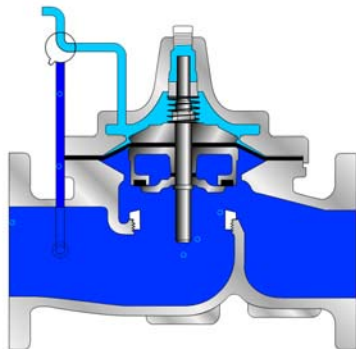

Full Open Operation:
 When pressure in the cover chamber is relieved to a lower pressure or to atmosphere, the pressure inlet opens the valve.

On/Off Control

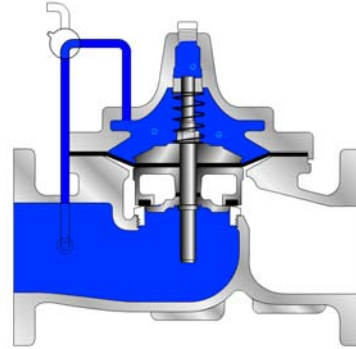

Tight Closing Operation:
 When pressure from the inlet pressure is applied to the cover chamber, the valve closes drip-tight.

CLA-VAL Controls

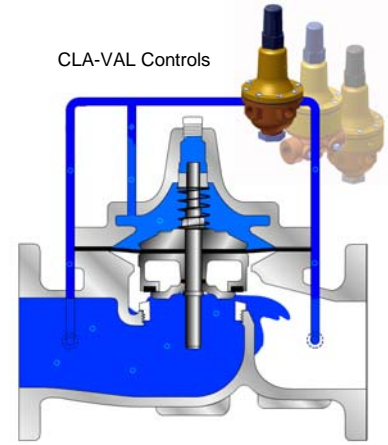

Modulating Control:
 The valve is pressure operating balanced. The CLA-VAL "Modulating" Controls will allow the valve to automatically compensate for pressure changes.

▶ Usual Main Valves

HYTROL Main Valve / HYTROL NGE-316	100-01
TYTAN Main Valve	100-01
HYTROL Auxiliary Valve	000130TT
ROLL SEAL Main Valve	100-42
DELUGE Main Valve	100G

▶ More Information

<input checked="" type="checkbox"/>	Schematic Diagram
<input checked="" type="checkbox"/>	Quick Valve Selection
<input checked="" type="checkbox"/>	Dimensions
<input checked="" type="checkbox"/>	Pressure Ratings & Materials

Sheet #	
	HYN001TT
	000121DE
	000122DE-1
	000123DE

► Cavitation / Flow Chart

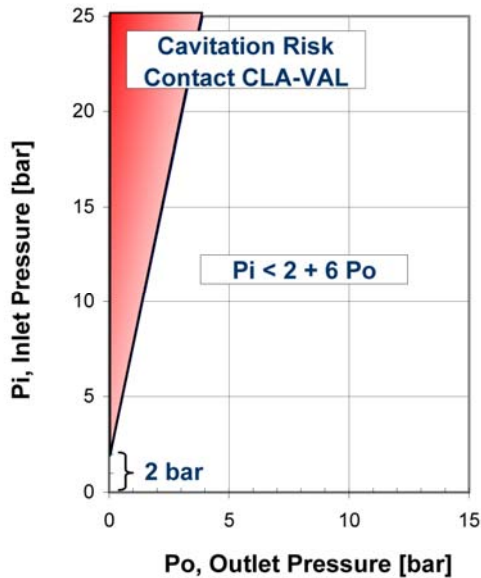

● **Valve Sizing Example**

Pipe Diameter : 100 [mm] }
 Peak Flow : 20 [l/s] } **NGE DN 100 [mm]**

Inlet Pressure : 15 [bar] }
 Outlet Pressure : 5 [bar] } **Below Cavitation Risk**

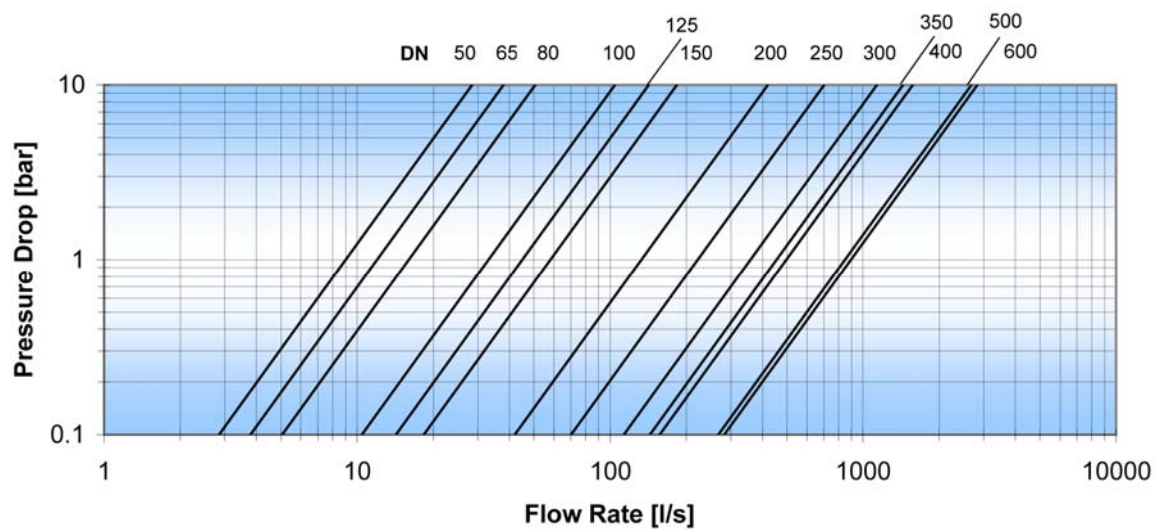

► Notes

- Diagram to be used as a guide only.

► More Information

- Quick Valve Selection
- Sizing Software

Sheet #
 000121DE
 Run CLA-VAL Softwares

► To obtain a more accurate calculation please contact CLA-VAL

▶ Performance Chart

Flanged [mm]	DN	32	40	50	65	80	100	125	150	200	250	300	350	400	450	500	600
Screwed [in]	DN	1 1/4"	1 1/2"	2"	2 1/2"	3"	-	-	-	-	-	-	-	-	-	-	-
Hytrol NGE																	
Kv (m3/h)		-	-	32	43	58	119	162	209	479	799	1292	1638	1789	2298	3049	3222
Cv (l/s) @ 1 bar		-	-	9	12	16	33	45	58	133	222	359	455	497	638	847	895
ζ (-)		-	-	9.5	15.3	19.8	11.3	14.9	18.6	11.2	9.8	7.8	8.9	12.8	12.4	10.8	20.0
Normal Flow (l/s)																	
@ velocity 1 m/s				1.6	2.7	4	6	10	14	25	39	56	77	100	127	157	226
@ velocity 3 m/s				to	to	to	to	to	to	to	to	to	to	to	to	to	to
				6	10	15	24	37	53	94	147	212	289	377	477	589	848
Max. Flow (l/s)																	
Continuous @ v=4 m/s		-	-	8	13	20	31	49	71	126	196	283	385	502	636	785	1130
Intermittent @ v=5.5 m/s		-	-	11	18	28	43	67	97	173	270	389	529	691	874	1079	1554

$$Q = Kv \sqrt{\Delta p}$$

$$Q = Cv \sqrt{\Delta p}$$

$$\Delta H = \zeta \frac{v^2}{2g}$$

Q : rate of flow (m3/h)
Kv : flow coefficient (m3/h)
Cv : flow coefficient (l/s)
 Δp : head loss (bar)

ΔH : head loss (m)
v : average pipe velocity (m/s)
g : gravitational constant (9.81m/s²)
 ζ : resistance coefficient (-)

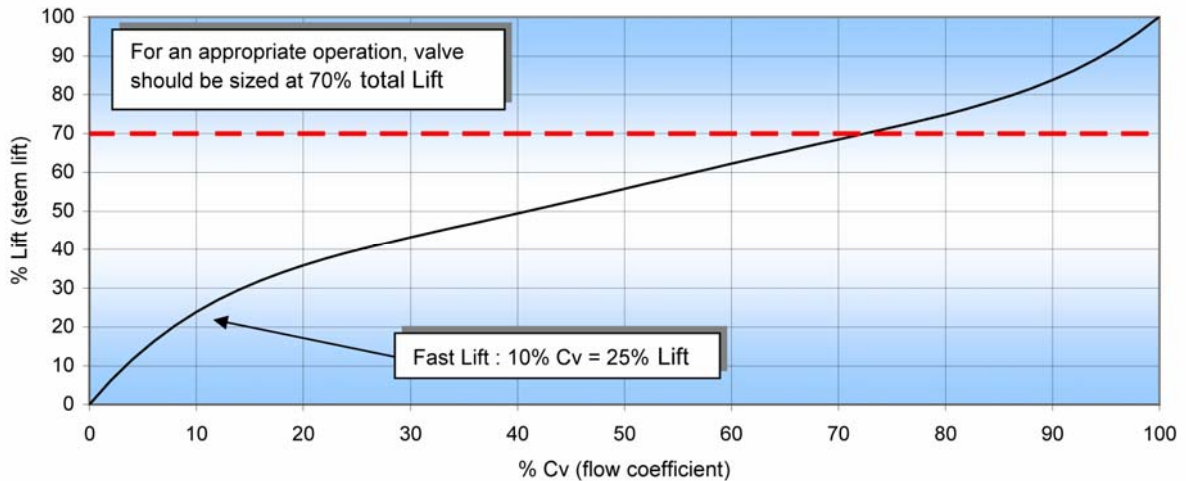

▶ Notes

- Kv or Cv = m3/h or l/s @ 100kPa (1 bar) head loss with 15°C water (valve totally open).
- Minimum Opening Pressure: 0,2 [bar].
- Minimum Differential Pressure: 0,5 [bar].

▶ More Information

- Quick Valve Selection
- Sizing Software

Sheet #

000121DE

Run CLA-VAL Softwares

▶ For lower opening Pressure or differential pressure, please contact CLA-VAL

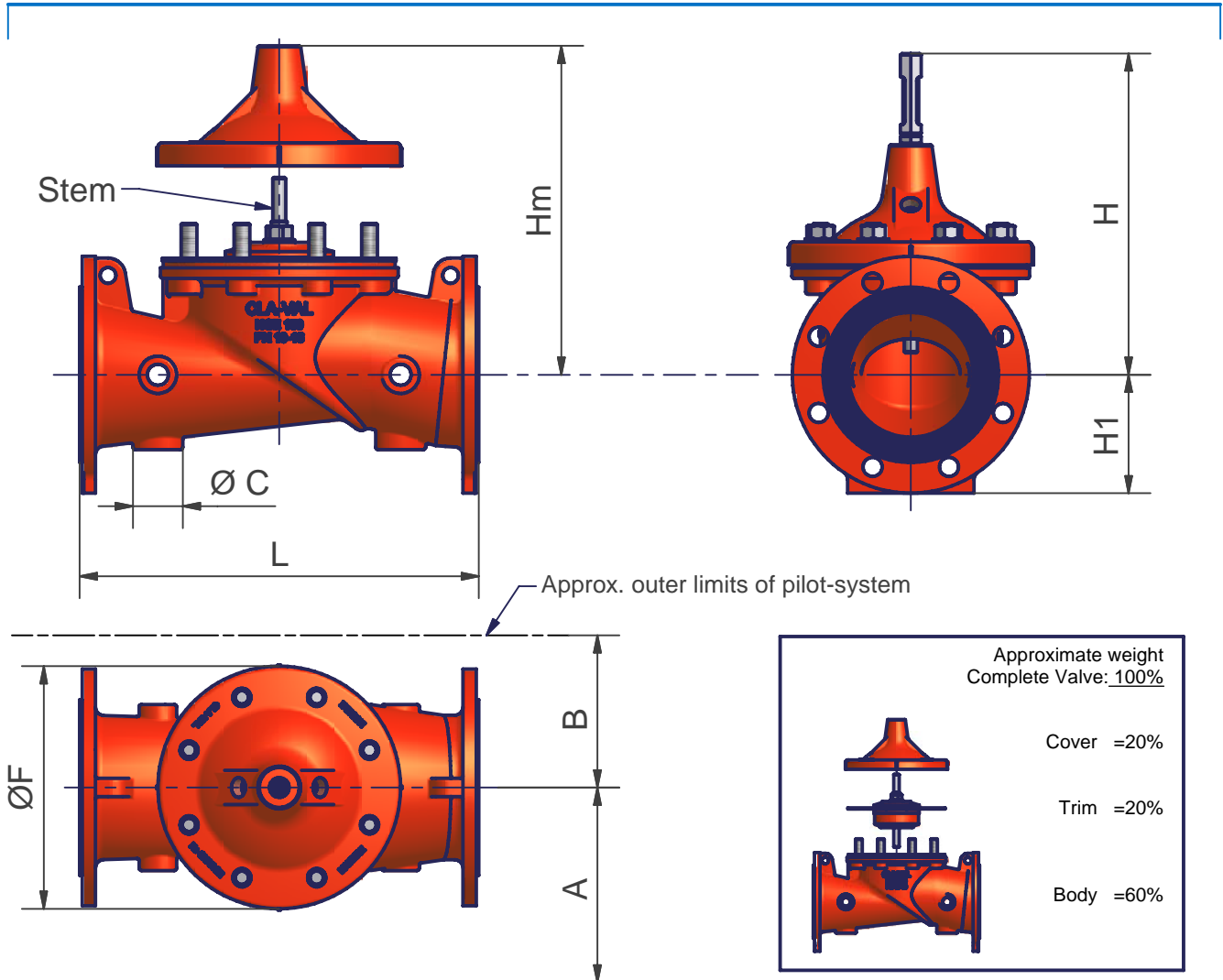

► Technical Data:

Flanged (mm)	DN 50	DN 65	DN 80	DN 100	DN 125	DN 150	DN 200	DN 250	DN 300	DN 350	DN 400	DN 450	DN 500	DN 600
L	230	290	310	350	400	480	600	730	850	980	1100	1200	1250	1450
F	145	170	170	235	295	295	400	510	600	712	712	712	900	900
H	195	225	230	305	365	375	460	547	695	821	821	900	1035	1035
H1 (PN10)	82.5	93	100	110	125	142.5	170	200	227.5	252.5	282.5	325	370	430
H1 (PN16)	82.5	93	100	110	125	142.5	170	200	227.5	260	290	325	370	430
H1 (PN25)	82.5	93	100	117.5	135	150	180	212.5	242.5	277.5	310	335	370	430
Hm	255	295	300	390	470	480	585	700	875	1030	1030	1200	1310	1310
A	190	200	200	200	235	250	270	290	365	400	425	450	520	520
B	145	150	150	160	160	165	200	200	345	385	380	420	460	460
øC	45	60	60	60	60	80	80	80	80	80	80	80	-	120
Weight (Kg)	15	20	25	40	60	70	120	190	330	540	640	700	980	1060

► Hydraulic Data:

Flanged (mm)	DN 50	DN 65	DN 80	DN 100	DN 125	DN 150	DN 200	DN 250	DN 300	DN 350	DN 400	DN 450	DN 500	DN 600
Kv (m ³ /h)	32	43	58	119	162	209	479	799	1292	1638	1789	2070	3049	3222
Cv (l/s)	9	12	16	33	45	58	133	222	359	455	497	575	847	895

Kv or Cv = m³/h or l/s @ 100kPa (1 bar) head loss with 15°C water (valve totally open).

▶ DN 50 to DN 600

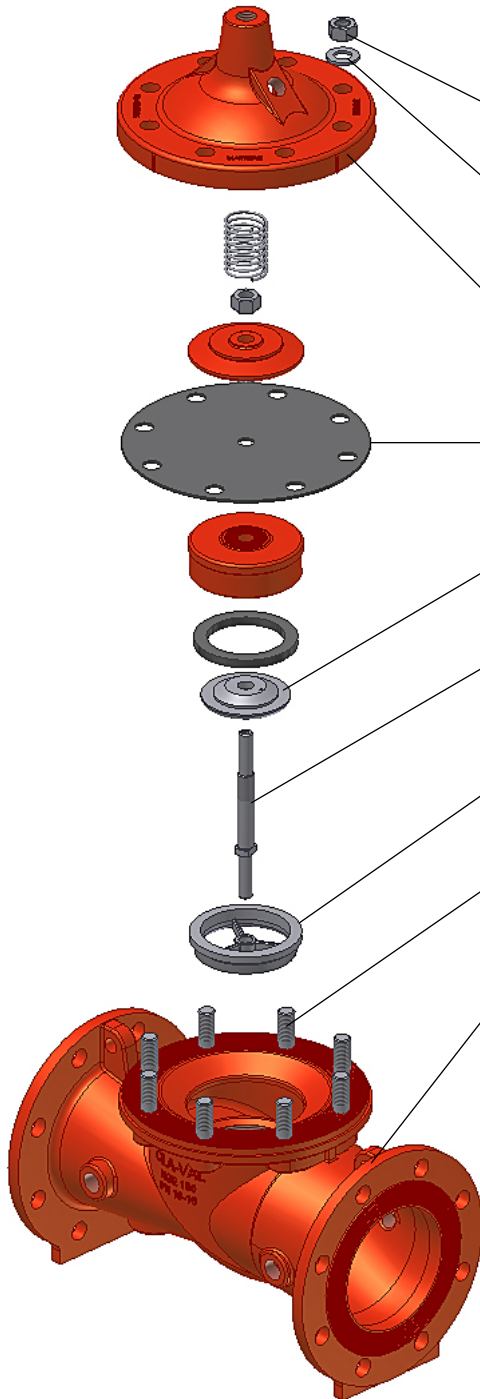

Standard Materials		
(3)	Stud nut	Stainless Steel
(29)	Washer	Stainless Steel
(6)	Cover	Ductile Iron
(9)	Diaphragm	Reinforced Rubber
(11)	Disc guide	Stainless Steel
(14)	Stem	Stainless Steel
(15)	Seat	Stainless Steel
(4)	Stud	Stainless Steel
(16)	Body	Ductile Iron

- Other Pressure Rating on request: PN 40, ANSI 150, ANSI 300.
- Standard epoxy coating minimum 250 microns.
- Auxiliary Valve HYTROL 3/8", 1/2", 3/4", 1" see 000130TT.

► DESCRIPTION

The CLA-VAL Model 100-01 HYTROL Valve is a main valve for CLA-VAL Automatic Control Valves. It is a hydraulically operated, diaphragm-actuated, globe or angle pattern valve.

This valve consists of three major components; body, diaphragm assembly, and cover. The diaphragm assembly is the only moving part. The diaphragm assembly uses a diaphragm of nylon fabric bonded with synthetic rubber. A synthetic rubber disc, contained on three and one half sides by a disc retainer and disc guide, forms a seal with the valve seat when pressure is applied above the diaphragm. The diaphragm assembly forms a sealed chamber in the upper portion of the valve, separating operating pressure from line pressure.

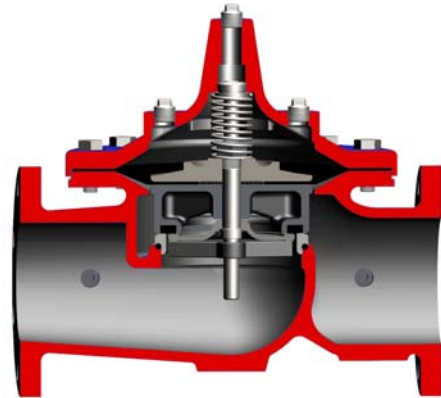

Illustration type GE

► INSTALLATION

1. Before valve is installed, pipe lines should be flushed of all chips, scale and foreign matter.
2. It is recommended that either gate or block valves be installed on both ends of the 100-01 HYTROL Valve to facilitate isolating the valve for preventive maintenance and repairs.
3. Place the valve in the line with flow through the valve in the direction indicated on the inlet nameplate. (See "Flow Direction" Section)
4. Allow sufficient room around valve to make adjustments and for disassembly.
5. CLA-VAL 100-01 HYTROL Valves operate with maximum efficiency when mounted in horizontal piping with the cover UP, however, other positions are acceptable. Due to size and weight of the cover and internal components of 8 inch and larger valves, installation with the cover UP is advisable. This makes internal parts readily accessible for periodic inspection.
6. Caution must be taken in the installation of this valve to insure that galvanic and/or electrolytic action does not take place. The proper use of dielectric fittings and gaskets are required in all systems using dissimilar metals.
7. If a pilot control system is installed on the 100-01 HYTROL Valve, use care to prevent damage. If it is necessary to remove fittings or components, be sure they are kept clean and replaced exactly as they were.
8. After the valve is installed and the system is first pressurized, vent air from the cover chamber and pilot system tubing by loosening fittings at all high points.

► FLOW DIRECTION

The flow through the 100-01 HYTROL Valve can be in one of two directions. When flow is "up-and-over the seat," it is in "normal" flow and the valve will fail in the open position. When flow is "over the seat-and down," it is in "reverse" flow and the valve will fail in the closed position. There are no permanent flow arrow markings.

The valve must be installed according to nameplate data.

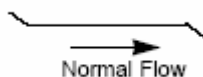

BRIDGEWALL INDICATOR
(cast into side of valve body)

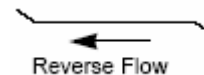

► RECOMMENDED TOOLS

1. Three pressure gauges with ranges suitable to the installation to be put at HYTROL inlet, outlet and cover connections.
2. CLA-VAL Model X101 Valve Position Indicator. This provides visual indication of valve position without disassembly of valve.
3. Other items are: suitable hand tools such as screwdrivers, wrenches, etc. soft jawed (brass or aluminum) vise 400 grit wet or dry sandpaper and water for cleaning.

▶ PRINCIPLES OF OPERATION

(Illustration type GE)

On/Off Control

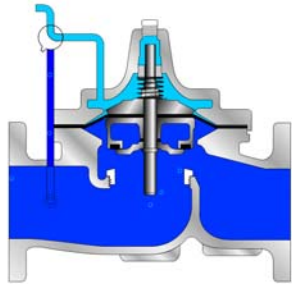

Tight Closing Operation

When pressure from the valve inlet (or an equivalent independent operating pressure) is applied to the diaphragm chamber the valve closes drip-tight.

On/Off Control

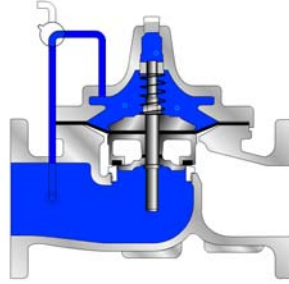

Full Open Operation

When pressure in diaphragm chamber is relieved to a zone of lower pressure (usually atmosphere) the line pressure (5 psi Min.) at the valve inlet opens the valve.

CLA-VAL control

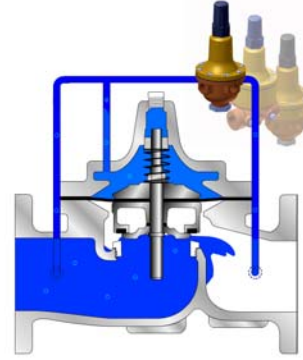

Modulating Action

Valve modulates when diaphragm pressure is held at an intermediate point between inlet and discharge pressure. With the use of a CLA-VAL. "modulating control," which reacts to line pressure changes, the pressure above the diaphragm is varied, allowing the valve to throttle and compensate for the change.

▶ THREE CHECKS

The 100-01 HYTROL Valve has only one moving part (the diaphragm and disc assembly). So, there are only three major types of problems to be considered.

First: Valve is stuck - that is, the diaphragm assembly is not free to move through a full stroke either from open to close or vice versa.

Second: Valve is free to move and can't close because of a worn out diaphragm.

Third: Valve leaks even though it is free to move and the diaphragm isn't leaking.

CAUTION! Care should be taken when doing the troubleshooting checks on the 100-01 HYTROL Valve. These checks do require the valve to open fully. This will either allow a high flow rate through the valve, or the downstream pressure will quickly increase to the inlet pressure. In some cases, this can be very harmful. Where this is the case, and there are no block valves in the system to protect the downstream piping, it should be realized that **the valve cannot be serviced under pressure**. Steps should be taken to remedy this situation before proceeding any further.

Valve size (DN)		COVER CHAMBER CAPACITY (liquid Volume displaced when valve opens)		STEM TRAVEL (Fully Open To Fully closed)	
NGE	GE	Liters	Gallons	mm	Inches
50	32 - 40	0,07	0,020	10,0	0,40
65 & 80	50	0,12	0,032	15,0	0,60
	65	0,16	0,043	18,0	0,70
100	80	0,30	0,080	20,0	0,80
125 & 150	100	0,64	0,169	28,0	1,10
200	150	2,00	0,531	43,0	1,70
250	200	4,80	1,260	58,0	2,30
300	250	9,50	2,510	71,0	2,80
350 & 400	300	15,10	4,000	86,0	3,40
	350	24,60	6,500	100,0	4,00
500 & 600	400	36,20	9,570	114,0	4,50
TYTAN		Liters	Gallons	mm	Inches
TYTAN-S	600 - 800	107,00	28,27	154,6	6,0
TYTAN-M	900 - 1000	159,00	42,00	190,0	7,5
TYTAN-L	900 - 1200	340,00	90,00	216,0	8,5



DIAPHRAGM CHECK (#1)

1. Shut off pressure to the HYTROL Valve by slowly closing upstream and downstream isolation valves. **SEE CAUTION!**
2. Disconnect or close all pilot control lines to the valve cover and leave only one fitting in highest point of cover open to atmosphere.
3. With the cover vented to atmosphere, slowly open upstream isolation valve to allow some pressure into the HYTROL Valve body. Observe the open cover tapping for signs of continuous flow. It is not necessary to fully open isolating valve. Volume in cover chamber capacity chart will be displaced as valve moves to open position. Allow sufficient time for diaphragm assembly to shift positions. If there is no continuous flow, you can be quite certain the diaphragm is sound and the diaphragm assembly is tight. If the fluid appears to flow continuously this is a good reason to believe the diaphragm is either damaged or it is loose on the stem. In either case, this is sufficient cause to remove the valve cover and investigate the leakage. (See "Maintenance" Section for procedure.)

FREEDOM OF MOVEMENT CHECK (#2)

4. Determining the HYTROL Valve's freedom of movement can be done by one of two methods.
5. For most valves it can be done after completing Diaphragm Check (Steps 1., 2., and 3.). **SEE CAUTION!** At the end of step 3. the valve should be fully open.
6. If the valve has a CLA-VAL X101 Position Indicator, observe the indicator to see that the valve opens wide. Mark the point of maximum opening.
7. Re-connect enough of the control system to permit the application of inlet pressure to the cover. Open pilot system cock so pressure flows from the inlet into the cover.
8. While pressure is building up in the cover, the valve should close smoothly. There is a hesitation in every HYTROL Valve closure, which can be mistaken for a mechanical bind. The stem will appear to stop moving very briefly before going to the closed position. This slight pause is caused by the diaphragm flexing at a particular point in the valve's travel and is not caused by a mechanical bind.
9. When closed, a mark should be made on the X101 Valve position indicator corresponding to the "closed" position. The distance between the two marks should be approximately the stem travel shown in chart.
10. If the stroke is different than that shown in stem travel chart this is a good reason to believe something is mechanically restricting the stroke of the valve at one end of its travel. If the flow does not stop through the valve when in the indicated "closed" position, the obstruction probably is between the disc and the seat. If the flow does stop, then the obstruction is more likely in the cover. In either case, the cover must be removed, and the obstruction located and removed. The stem should also be checked for scale build-up. (See "Maintenance, section for procedure.)
11. For valves 6" and smaller, the HYTROL Valve's freedom of movement check can also be done after all pressure is removed from the valve. **SEE CAUTION!** After closing inlet and outlet isolation valves and bleeding pressure from the valve, check that the cover chamber and the body are temporarily vented to atmosphere. Insert fabricated tool into threaded hole in top of valve stem, and lift the diaphragm assembly manually. Note any roughness. The diaphragm assembly should move smoothly throughout entire valve stroke. The tool is fabricated from rod that is threaded on one end to fit valve stem and has a "T" bar handle of some kind on the other end for easy gripping. (See chart in Step 4 of "Disassembly" Section.)
12. Place marks on this diaphragm assembly lifting tool when the valve is closed and when manually positioned open. The distance between the two marks should be approximately the stem travel shown in stem travel chart. If the stroke is different than that shown, there is a good reason to believe something is mechanically restricting the stroke of the valve. The cover must be removed, and the obstruction located and removed. The stem should also be checked for scale build-up. (See "Maintenance, section for procedure.)

TIGHT SEALING CHECK (#3)

13. Test for seat leakage after completing checks #1 & #2 (Steps 1. to 12.). **SEE CAUTION!** Close the isolation valve downstream of the HYTROL Valve. Apply inlet pressure to the cover of the valve, wait until it closes. Install a pressure gauge between the two closed valves using one of the two ports in the outlet side of the HYTROL. Watch the pressure gauge. If the pressure begins to climb, then either the downstream isolation valve is permitting pressure to creep back, or the HYTROL is allowing pressure to go through it. Usually the pressure at the HYTROL inlet will be higher than on the isolation valve discharge, so if the pressure goes up to the inlet pressure, you can be sure the HYTROL is leaking. Install another gauge downstream of isolating valve. If the pressure between the valves only goes up to the pressure on the isolation valve discharge, the HYTROL Valve is holding tight, and it was just the isolation valve leaking.

▶ TROUBLESHOOTING

The following troubleshooting information deals strictly with the Model 100-01 HYTROL Valve. This assumes that all other components of the pilot control system have been checked out and are in proper working condition. (See appropriate sections in Technical Manual for complete valve).

All trouble shooting is possible without removing the valve from the line or removing the cover. It is highly recommended to permanently install a Model X101 Valve Position Indicator and three gauges in unused HYTROL inlet, outlet and cover connections.

SYMPTOM	PROBABLE CAUSE	REMEDY
Fails to close	Closed isolation valves in control system, or in main line.	Open Isolation valves.
	Lack of cover chamber pressure.	Check upstream pressure, pilot system, strainer, tubing, valves, or needle valves for obstruction.
	Diaphragm damaged. (See Diaphragm Check)	Replace diaphragm.
	Diaphragm assembly inoperative. Corrosion or excessive scale build-up on valve stem. (See Freedom of Movement Check)	Clean and polish stem. Inspect and replace any damaged or badly eroded part.
	Mechanical obstruction. Object lodged in valve. (See Freedom of Movement Check)	Remove obstruction.
	Worn disc. (See Tight Sealing Check)	Replace disc.
	Badly scored seat. (See Tight Sealing Check)	Replace seat.
Fails to open	Closed upstream and/or downstream isolation valves in main line.	Open isolation valves.
	Insufficient line pressure.	Check upstream pressure. (Minimum 5 psi flowing line pressure differential.)
	Diaphragm assembly inoperative. Corrosion or excessive build-up on valve stem. (See Freedom of Movement Check)	Clean and polish stem. Inspect and replace any damaged or badly eroded part.
	Diaphragm damaged. (For valves in "reverse flow" only)	Replace diaphragm.

After checking out probable causes and remedies, the following three checks can be used to diagnose the nature of the problem before maintenance is started. They must be done in the order shown.

▶ MAINTENANCE

PREVENTATIVE MAINTENANCE

The CLA-VAL Model 100-01 HYTROL Valve requires no lubrication or packing and a minimum of maintenance. However, a periodic inspection schedule should be established to determine how the operating conditions of the system are affecting the valve. The effect of these actions must be determined by inspection.

DISASSEMBLY

Inspection or maintenance can be accomplished without removing the valve from the line. Repair kits with new diaphragm and disc are recommended to be on hand before work begins.



SEE CAUTION! Maintenance personnel can be injured and equipment damaged if disassembly is attempted with pressure in the valve.

1. Close upstream and downstream isolation valves **and independent operating pressure when used** to shut off all pressure to the valve.
2. Loosen tube fittings in the pilot system to remove pressure from valve body and cover chamber. After pressure has been released from the valve, use care to remove the controls and tubing. Note and sketch position of tubing and controls for re-assembly. The schematic in front of the Technical Manual can be used as a guide when reassembling pilot system.
3. Remove cover nuts and remove cover. If the valve has been in service for any length of time, chances are the cover will have to be loosened by driving upward along the edge of the cover with a **dull** cold chisel.

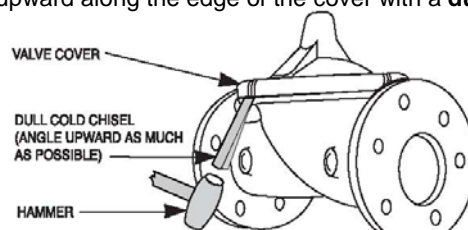

On 6" and smaller valves block and tackle or a power hoist can be used to lift valve cover by inserting proper size eye bolt in place of the center cover plug. On 8" and larger valves there are 4 holes (5/8" - 11 size) where jacking screws and/or eye bolts may be inserted for lifting purposes. **Pull cover straight up** to keep from damaging the integral seat bearing and stem.

COVER CENTER PLUG SIZE		
Valve size		Thread Size (NPT)
NGE	GE / AE	
DN 50	DN 32 - 40	1/4"
DN 65 - 100	DN 50 - 80	1/2"
DN 125 - 200	DN 100 - 150	3/4"
DN 250 - 300	DN 200 - 250	1"
DN 650 - 400	DN 300	1 1/4"
-	DN 350	1 1/2"
DN 500 - 600	DN 400	2"
TYTAN-S	DN 600 - 800	1"
TYTAN-M	DN 900 - 1000	2"
TYTAN-L	DN 900 - 1200	2"

4. Remove the diaphragm and disc assembly from the valve body. With smaller valves this can be accomplished by hand by **pulling straight up on the stem so as not to damage the seat bearing**. On large valves, an eye bolt of proper size can be installed in the stem and the diaphragm assembly can be then lifted with a block and tackle or power hoist. Take care not to damage the stem or bearings. The valve won't work if these are damaged.

VALVE STEM THREAD SIZE		
Valve size		Thread Size (Internal)
NGE	GE / AE	
DN 50 - 80	DN 32 - 65	10 - 32 UNF
DN 100 - 150	DN 80 - 100	1/4 - 28 UNF
DN 200 - 400	DN 150 - 350	3/8 - 24 UNF
DN 500 - 600	DN 400	1/2 - 20 UNF
TYTAN-S	DN 600 - 800	1/2 - 20 UNF
TYTAN-M	DN 900 - 1000	M20
TYTAN-L	DN 900 - 1200	M20

5. The next item to remove is the stem nut. Examine the stem threads above the nut for signs of mineral deposits or corrosion. If the threads are not clean, use a wire brush to remove as much of the residue as possible. Attach a good fitting wrench to the nut and give it a sharp "rap" rather than a steady pull. Usually several blows are sufficient to loosen the nut for further removal. On the smaller valves, the entire diaphragm assembly can be held by the stem in a vise **equipped with soft brass jaws** before removing the stem nut.

The use of a pipe wrench or a vise without soft brass jaws scars the fine finish on the stem. No amount of careful dressing can restore the stem to its original condition. Damage to the finish of the stem can cause the stem to bind in the bearings and the valve will not open or close.

6. After the stem nut has been removed, the diaphragm assembly breaks down into its component parts. Removal of the disc from the disc retainer can be a problem if the valve has been in service for a long time. Using two screwdrivers inserted along the outside edge of the disc usually will accomplish its removal. Care should be taken to preserve the spacer washers in water, particularly if no new ones are available for re-assembly.
7. The only part left in the valve body is the seat which ordinarily does not require removal. Careful cleaning and polishing of inside and outside surfaces with 400 wet/dry sandpaper will usually restore the seat's sharp edge. If, however, it is badly worn and replacement is necessary, it can be easily removed.

Seats in valve sizes 1 1/4" through 6" are threaded into the valve body. They can be removed with accessory X109 Seat Removing Tool available from the factory. On 8" and larger valves, the seat is held in place by flat head machine screws. Use a tight-fitting, long shank screwdriver to prevent damage to seat screws. If upon removal of the screws the seat cannot be lifted out, it will be necessary to use a piece of angle or channel iron with a hole drilled in the center. Place it across the body so a long stud can be inserted through the center hole in the seat and the hole in the angle iron. By tightening the nut a uniform upward force is exerted on the seat for removal.

Note: Do not lift up on the end of the angle iron as this may force the integral bearing out of alignment, causing the stem to bind.

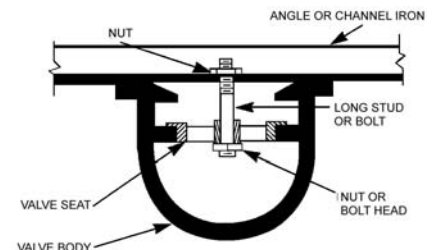



INSPECTION OF PARTS

After the valve has been disassembled, each part should be examined carefully for signs of wear, corrosion, or any other abnormal condition. Usually, it is a good idea to replace the rubber parts (diaphragm and disc) unless they are free of signs of wear. These are available in a repair kit. Any other parts which appear doubtful should be replaced. **WHEN ORDERING PARTS, BE SURE TO GIVE COMPLETE NAMEPLATE DATA, ITEM NUMBER AND DESCRIPTION.**

Note: If a new disc isn't available, the existing disc can be turned over, exposing the unused surface for contact with the seat. The disc should be replaced as soon as practical.

REASSEMBLY

1. Reassembly is the reverse of the disassembly procedure. If a new disc has been installed, it may require a different number of spacer washers to obtain the right amount of "grip" on the disc. When the diaphragm assembly has been tightened to a point where the diaphragm cannot be twisted, the disc should be compressed very slightly by the disc guide. Excessive compression should be avoided. Use just enough spacer washers to hold the disc firmly without noticeable compression.
2. **MAKE SURE THE STEM NUT IS VERY TIGHT.** Attach a good fitting wrench to the nut and give it a sharp "rap" rather than a steady pull. Usually several blows are sufficient to tighten the stem nut for final tightening. Failure to do so could allow the diaphragm to pull loose and tear when subjected to pressure.
3. Carefully install the diaphragm assembly by lowering the stem through the seat bearing. Take care not to damage the stem or bearing. Line up the diaphragm holes with the stud or bolt holes on the body. On larger valves with studs, it may be necessary to hold the diaphragm assembly up part way while putting the diaphragm over the studs.
4. Put spring in place and replace cover. Make sure diaphragm is lying smooth under the cover.
5. Tighten cover nuts firmly using a cross-over pattern until all nuts are tight.
6. Test HYTROL Valve before re-installing pilot valve system.

TEST PROCEDURE AFTER VALVE ASSEMBLY

There are a few simple tests which can be made in the field to make sure the HYTROL Valve has been assembled properly. Do these before installing pilot system and returning valve to service. These are similar to the three troubleshooting tests.

- 1- Check the diaphragm assembly for freedom of movement after all pressure is removed from the valve. **SEE CAUTION!** Insert fabricated tool into threaded hole in top of valve stem, and lift the diaphragm assembly manually. Note any roughness, sticking or grabbing. The diaphragm assembly should move smoothly throughout entire valve stroke. The tool is fabricated from rod that is threaded on one end to fit valve stem (See chart in Step 4 of "Disassembly" section.) and has a "T" Bar handle of some kind on the other end for easy gripping.
Place marks on this diaphragm assembly lifting tool when the valve is closed and when manually positioned open. The distance between the two marks should be approximately the stem travel shown in stem travel chart. (See "Freedom of Movement Check" section.) If the stroke is different than that shown, there is a good reason to believe something is mechanically restricting the stroke of the valve. The cover must be removed, the obstruction located and removed. (See "Maintenance" Section for procedure.) Due to the weight of the diaphragm assembly this procedure is not possible on valves 8" and larger. on these valves, the same determination can be made by carefully introducing a low pressure-less than five psi) into the valve body with the cover vented. **SEE CAUTION!** Looking in cover center hole see the diaphragm assembly lift easily without hesitation, and then settle back easily when the pressure is removed.
- 2- To check the valve for drip-tight closure, a line should be connected from the inlet to the cover, and pressure applied at the inlet of the valve. If properly assembled, the valve should hold tight with as low as ten PSI at the inlet. See "Tight Sealing Check" section.)
- 3- With the line connected from the inlet to the cover, apply full working pressure to the inlet. Check all around the cover for any leaks. Re-tighten cover nuts if necessary to stop leaks past the diaphragm.
- 4- Remove pressure, then re-install the pilot system and tubing exactly as it was prior to removal. **Bleed air from all high points.**
- 5- Follow steps under "Start-Up and Adjustment" Section in Technical Manual for returning complete valve back to service.

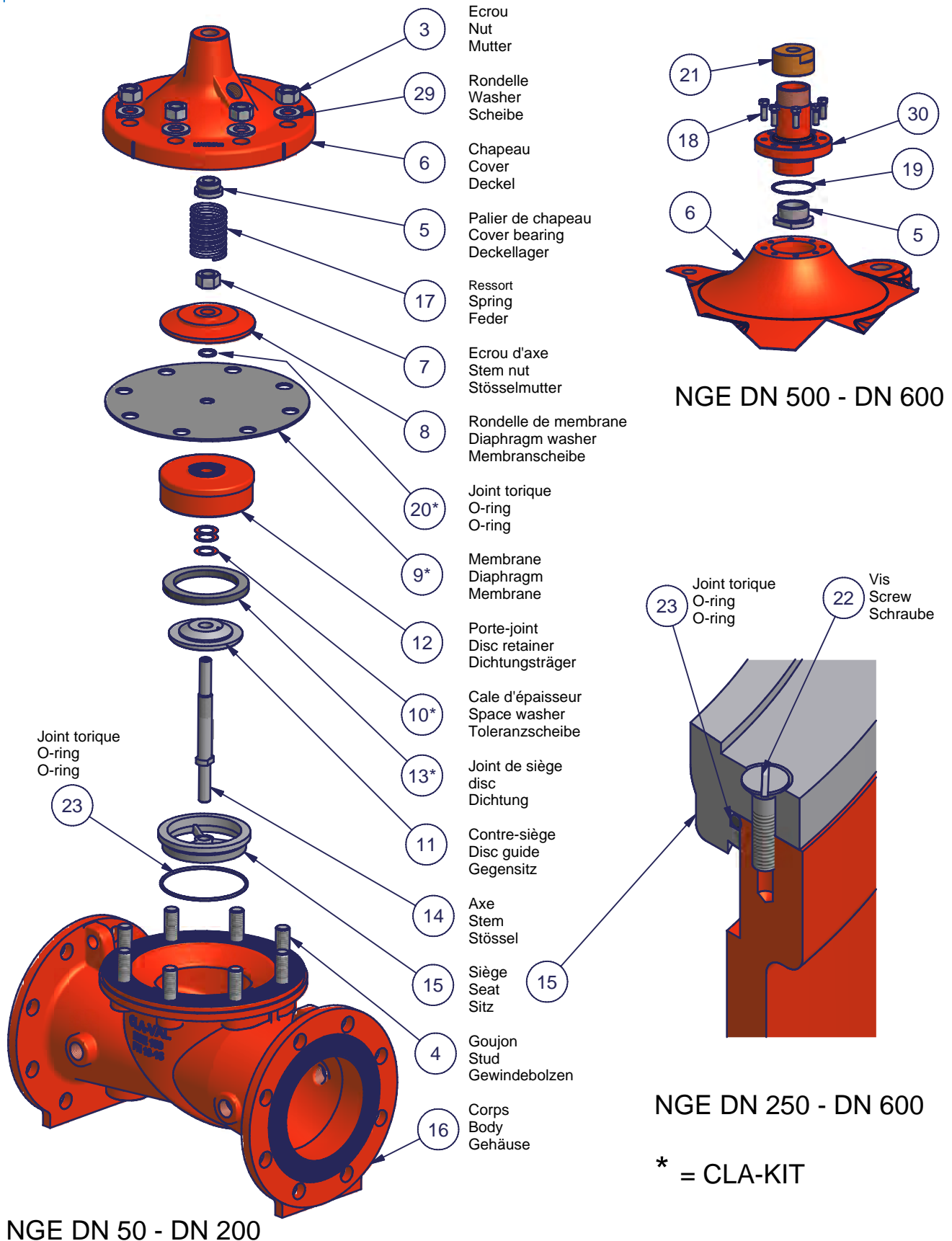

► STD: STANDARD

PIECE DE RECHANGE / SPARE PARTS / ERSATZTEILE

KIT DE REPARATION / REPAIR KIT / REPARATURSATZ		
(a)	CLA-KIT HYTROL100-01 - GE 40/PN 10 - 16	91698-04
(b)	CLA-KIT HYTROL100-01 - GE 40/PN 25	🔧 CLA-VAL

POS.	DESCRIPTION	DESCRIPTION	BESCHREIBUNG	MAT.	CLA-VAL Nr.
1	Bouchon-purgeur	Air release plug	Entlüftungstopfen	303	57576
2	Bouchon	Cover plug	Stopfen	316	BGT2001
3	Ecrou	Stud nut	Mutter	303	67799-08A
4	Goujon	Stud	Gewindebolzen	303	57621-01
5	Palier de chapeau	Cover bearing	Deckellager	303	57933
6	Chapeau	Cover	Deckel	FD4	57185-40
7	Ecrou d'axe	Stem nut	Stößelmutter	303	89375-01J
8	Rondelle de membrane	Diaphragm washer	Membranscheibe	PLA	2960701H
9	Membrane	Diaphragm	Membrane	RBR	83239E (a)
9.1	Membrane (PN25)	Diaphragm (PN25)	Membrane (PN25)	RBR	83239E (2x) (b)
10	Cale d'épaisseur	Space washer	Toleranzscheibe	FIB	V-5180E (a/b)
11	Contre-siège	Disc guide	Gegensitz	316	C-5446E
12	Porte-joint	Disc retainer	Dichtungsträger	303	C-1862G
13	Joint de siège	Disc	Dichtung	RBR	V-5562D (a/b)
13.1	Joint de siège (***)	Disc (***)	Dichtung (***)	PET	21589-01F (b***)
14	Axe	Stem	Stößel	303	57286
15	Siège	Seat	Sitz	316	C-1425C
16	Corps	Body	Gehäuse	FD4	(**)
17	Ressort	Spring	Feder	302	C-8477G
17.1	Ressort renforcé (PN25)	Spring heavy (PN25)	Verstärkte Feder (PN25)	302	C-8476G
20	Joint torique	O-ring	O-Ring	RBR	00713J (a/b)
23	Joint torique	O-ring	O-Ring	RBR	00731A
25	Bouchon	Plug	Stopfen	316	BGT2001
29	Rondelle plate	Washer	Unterlegscheibe	303	67747-04J

(**) Voir / See / Siehe HYT016F

(***) Recommandé si $\Delta P > 16$ bar / Recommended if $\Delta P > 16$ bar / Empfohlen wenn $\Delta P > 16$ bar

KC: Revêtement époxy / Standard epoxy coating / Epoxy-Pulverbeschichtung (minimum 250 μ m)

KCO: KC + Visserie en acier inoxydable / Stainless steel bolts / Deckelschrauben aus Edelstahl

KCS: KC + Siège et contre-siège en acier inoxydable / Stainless steel seat and guide / Sitz und Gegensitz aus Edelstahl

KCOS: KCO + KCS.

► STD: STANDARD

PIECE DE RECHANGE / SPARE PARTS / ERSATZTEILE

KIT DE REPARATION / REPAIR KIT / REPARATURSATZ		
(a)	CLA-KIT HYTROL100-01 - GE 50/PN 10 - 16	91698-05
(b)	CLA-KIT HYTROL100-01 - GE 50/PN 25	🔧 CLA-VAL

POS.	DESCRIPTION	DESCRIPTION	BESCHREIBUNG	MAT.	CLA-VAL Nr.
1	Bouchon-purgeur	Air release plug	Entlüftungstopfen	303	57576
2	Bouchon	Cover plug	Stopfen	316	BGT2001
3	Ecrou	Stud nut	Mutter	303	67801-08E
4	Goujon	Stud	Gewindebolzen	303	57621-02
5	Palier de chapeau	Cover bearing	Deckellager	303	57934
6	Chapeau	Cover	Deckel	FD4	57186-40
7	Ecrou d'axe	Stem nut	Stößelmutter	303	89376-01G
8	Rondelle de membrane	Diaphragm washer	Membranscheibe	PLA	2665501K
9	Membrane	Diaphragm	Membrane	RBR	80522G (a)
9.1	Membrane (PN25)	Diaphragm (PN25)	Membrane (PN25)	RBR	C-1493-01 (b)
10	Cale d'épaisseur	Space washer	Toleranzscheibe	FIB	V-5232D (a/b)
11	Contre-siège	Disc guide	Gegensitz	316	32560F
12	Porte-joint	Disc retainer	Dichtungsträger	303	57383-01
13	Joint de siège	Disc	Dichtung	RBR	V-5564K (a/b)
13.1	Joint de siège (***)	Disc (***)	Dichtung (***)	PET	21265-01C (b***)
14	Axe	Stem	Stößel	303	57287
15	Siège	Seat	Sitz	316	C-4135-01C
16	Corps	Body	Gehäuse	FD4	(**)
17	Ressort	Spring	Feder	302	C-3147A
17.1	Ressort renforcé (PN25)	Spring heavy (PN25)	Verstärkte Feder (PN25)	316	C-3152A
20	Joint torique	O-ring	O-Ring	RBR	00714G (a/b)
23	Joint torique	O-ring	O-Ring	RBR	00775H
25	Bouchon	Plug	Stopfen	316	BGT2001
29	Rondelle plate	Washer	Unterlegscheibe	303	67748-04G

(**) Voir / See / Siehe HYT016F

(***) Recommandé si $\Delta P > 16$ bar / Recommended if $\Delta P > 16$ bar / Empfohlen wenn $\Delta P > 16$ bar

KC: Revêtement époxy / Standard epoxy coating / Epoxy-Pulverbeschichtung (minimum 250 μ m)

KCO: KC + Visserie en acier inoxydable / Stainless steel bolts / Deckelschrauben aus Edelstahl

KCS: KC + Siège et contre-siège en acier inoxydable / Stainless steel seat and guide / Sitz und Gegensitz aus Edelstahl

KCOS: KCO + KCS.

► STD: STANDARD

PIECE DE RECHANGE / SPARE PARTS / ERSATZTEILE

KIT DE REPARATION / REPAIR KIT / REPARATURSATZ		
(a)	CLA-KIT HYTROL100-01 - GE 50/PN 10 - 16	91698-05
(b)	CLA-KIT HYTROL100-01 - GE 50/PN 25	🔧 CLA-VAL

POS.	DESCRIPTION	DESCRIPTION	BESCHREIBUNG	MAT.	CLA-VAL Nr.
1	Bouchon-purgeur	Air release plug	Entlüftungstopfen	303	57576
2	Bouchon	Cover plug	Stopfen	316	BGT2001
3	Ecrou	Stud nut	Mutter	303	67801-08E
4	Goujon	Stud	Gewindebolzen	303	57621-02
5	Palier de chapeau	Cover bearing	Deckellager	303	57934
6	Chapeau	Cover	Deckel	FD4	57186-40
7	Ecrou d'axe	Stem nut	Stößelmutter	303	89376-01G
8	Rondelle de membrane	Diaphragm washer	Membranscheibe	PLA	2665501K
9	Membrane	Diaphragm	Membrane	RBR	80522G (a)
9.1	Membrane (PN25)	Diaphragm (PN25)	Membrane (PN25)	RBR	C-1493-01 (b)
10	Cale d'épaisseur	Space washer	Toleranzscheibe	FIB	V-5232D (a/b)
11	Contre-siège	Disc guide	Gegensitz	316	32560F
12	Porte-joint	Disc retainer	Dichtungsträger	303	57383-01
13	Joint de siège	Disc	Dichtung	RBR	V-5564K (a/b)
13.1	Joint de siège (***)	Disc (***)	Dichtung (***)	PET	21265-01C (b***)
14	Axe	Stem	Stößel	303	57287
15	Siège	Seat	Sitz	316	C-4135-01C
16	Corps	Body	Gehäuse	FD4	(**)
17	Ressort	Spring	Feder	302	C-3147A
17.1	Ressort renforcé (PN25)	Spring heavy (PN25)	Verstärkte Feder (PN25)	316	C-3152A
20	Joint torique	O-ring	O-Ring	RBR	00714G (a/b)
23	Joint torique	O-ring	O-Ring	RBR	00775H
25	Bouchon	Plug	Stopfen	316	BGT2001
29	Rondelle plate	Washer	Unterlegscheibe	303	67748-04G

(**) Voir / See / Siehe HYT016F

(***) Recommandé si $\Delta P > 16$ bar / Recommended if $\Delta P > 16$ bar / Empfohlen wenn $\Delta P > 16$ bar

KC: Revêtement époxy / Standard epoxy coating / Epoxy-Pulverbeschichtung (minimum 250 μ m)

KCO: KC + Visserie en acier inoxydable / Stainless steel bolts / Deckelschrauben aus Edelstahl

KCS: KC + Siège et contre-siège en acier inoxydable / Stainless steel seat and guide / Sitz und Gegensitz aus Edelstahl

KCOS: KCO + KCS.

► STD: STANDARD

PIECE DE RECHANGE / SPARE PARTS / ERSATZTEILE

KIT DE REPARATION / REPAIR KIT / REPARATURSATZ		
(a)	CLA-KIT HYTROL100-01 - GE 80/PN 10 - 16	91698-12
(b)	CLA-KIT HYTROL100-01 - GE 80/PN 25	📞 CLA-VAL

POS.	DESCRIPTION	DESCRIPTION	BESCHREIBUNG	MAT.	CLA-VAL Nr.
1	Bouchon-purgeur	Air release plug	Entlüftungstopfen	303	57576-02
2	Bouchon	Cover plug	Stopfen	316	BGT3001
3	Ecrou	Stud nut	Mutter	303	67805-08F
4	Goujon	Stud	Gewindebolzen	303	57621-04
5	Palier de chapeau	Cover bearing	Deckellager	303	57935
6	Chapeau	Cover	Deckel	FD4	57188-40
7	Ecrou d'axe	Stem nut	Stößelmutter	303	89377-01E
8	Rondelle de membrane	Diaphragm washer	Membranscheibe	FTG	V-5447/KC
9	Membrane	Diaphragm	Membrane	RBR	83241A (a)
9.1	Membrane (PN25)	Diaphragm (PN25)	Membrane (PN25)	RBR	C-8262C (b)
10	Cale d'épaisseur	Space washer	Toleranzscheibe	FIB	V-0631B (a/b)
11	Contre-siège	Disc guide	Gegensitz	316	C-7389E
12	Porte-joint	Disc retainer	Dichtungsträger	FTG	V-5449/KC
13	Joint de siège	Disc	Dichtung	RBR	V-1734C (a/b)
13.1	Joint de siège (***)	Disc (***)	Dichtung (***)	PET	21267-01J (b***)
14	Axe	Stem	Stößel	303	57289
15	Siège	Seat	Sitz	316	C-7391A
16	Corps	Body	Gehäuse	FD4	(**)
17	Ressort	Spring	Feder	302	C-3149G
17.1	Ressort renforcé (PN25)	Spring heavy (PN25)	Verstärkte Feder (PN25)	316	C-1106J
20	Joint torique	O-ring	O-Ring	RBR	00750A (a/b)
23	Joint torique	O-ring	O-Ring	RBR	00788A
25	Bouchon	Plug	Stopfen	316	BGT3001
29	Rondelle plate	Washer	Unterlegscheibe	303	67750-04C

(**) Voir / See / Siehe HYT016F

(***) Recommandé si $\Delta P > 16$ bar / Recommended if $\Delta P > 16$ bar / Empfohlen wenn $\Delta P > 16$ bar

KC: Revêtement époxy / Standard epoxy coating / Epoxy-Pulverbeschichtung (minimum 250 μ m)

KCO: KC + Visserie en acier inoxydable / Stainless steel bolts / Deckelschrauben aus Edelstahl

KCS: KC + Siège et contre-siège en acier inoxydable / Stainless steel seat and guide / Sitz und Gegensitz aus Edelstahl

KCOS: KCO + KCS.

► STD: STANDARD

PIECE DE RECHANGE / SPARE PARTS / ERSATZTEILE

KIT DE REPARATION / REPAIR KIT / REPARATURSATZ		
(a)	CLA-KIT HYTROL100-01 - GE 100/PN 10 - 16	91698-13
(b)	CLA-KIT HYTROL100-01 - GE 100/PN 25	🔧 CLA-VAL

POS.	DESCRIPTION	DESCRIPTION	BESCHREIBUNG	MAT.	CLA-VAL Nr.
1	Bouchon-purgeur	Air release plug	Entlüftungstopfen	303	57576-02
2	Bouchon	Cover plug	Stopfen	316	BGT4001
3	Ecrou	Stud nut	Mutter	303	67811-08D
4	Goujon	Stud	Gewindebolzen	303	37048-02C
5	Palier de chapeau	Cover bearing	Deckellager	303	57936
6	Chapeau	Cover	Deckel	FD4	57189-40
7	Ecrou d'axe	Stem nut	Stößelmutter	303	89378-01C
8	Rondelle de membrane	Diaphragm washer	Membranscheibe	FTG	V-5420/KC
9	Membrane	Diaphragm	Membrane	RBR	86807F (a)
9.1	Membrane (PN25)	Diaphragm (PN25)	Membrane (PN25)	RBR	C-8184J (b)
10	Cale d'épaisseur	Space washer	Toleranzscheibe	FIB	V-0634F (a/b)
11	Contre-siège	Disc guide	Gegensitz	316	31052E
12	Porte-joint	Disc retainer	Dichtungsträger	FTG	V-5457/KC
13	Joint de siège	Disc	Dichtung	RBR	V-5467F (a/b)
13.1	Joint de siège (***)	Disc (***)	Dichtung (***)	PET	21268-01G (b***)
14	Axe	Stem	Stößel	303	57290
15	Siège	Seat	Sitz	316	31053C
16	Corps	Body	Gehäuse	FD4	(**)
17	Ressort	Spring	Feder	302	C-1533D
17.1	Ressort renforcé (PN25)	Spring heavy (PN25)	Verstärkte Feder (PN25)	302	C-1408J
20	Joint torique	O-ring	O-Ring	RBR	00752G (a/b)
23	Joint torique	O-ring	O-Ring	RBR	00836H
25	Bouchon	Plug	Stopfen	316	BGT4001
29	Rondelle plate	Washer	Unterlegscheibe	303	67753-04G

(**) Voir / See / Siehe HYT016F

(***) Recommandé si $\Delta P > 16$ bar / Recommended if $\Delta P > 16$ bar / Empfohlen wenn $\Delta P > 16$ bar

KC: Revêtement époxy / Standard epoxy coating / Epoxy-Pulverbeschichtung (minimum 250 μ m)

KCO: KC + Visserie en acier inoxydable / Stainless steel bolts / Deckelschrauben aus Edelstahl

KCS: KC + Siège et contre-siège en acier inoxydable / Stainless steel seat and guide / Sitz und Gegensitz aus Edelstahl

KCOS: KCO + KCS.

► STD: STANDARD

PIECE DE RECHANGE / SPARE PARTS / ERSATZTEILE

KIT DE REPARATION / REPAIR KIT / REPARATURSATZ		
(a)	CLA-KIT HYTROL100-01 - GE 100/PN 10 - 16	91698-13
(b)	CLA-KIT HYTROL100-01 - GE 100/PN 25	🔧 CLA-VAL

POS.	DESCRIPTION	DESCRIPTION	BESCHREIBUNG	MAT.	CLA-VAL Nr.
1	Bouchon-purgeur	Air release plug	Entlüftungstopfen	303	57576-02
2	Bouchon	Cover plug	Stopfen	316	BGT4001
3	Ecrou	Stud nut	Mutter	303	67811-08D
4	Goujon	Stud	Gewindebolzen	303	37048-02C
5	Palier de chapeau	Cover bearing	Deckellager	303	57936
6	Chapeau	Cover	Deckel	FD4	57189-40
7	Ecrou d'axe	Stem nut	Stößelmutter	303	89378-01C
8	Rondelle de membrane	Diaphragm washer	Membranscheibe	FTG	V-5420/KC
9	Membrane	Diaphragm	Membrane	RBR	86807F (a)
9.1	Membrane (PN25)	Diaphragm (PN25)	Membrane (PN25)	RBR	C-8184J (b)
10	Cale d'épaisseur	Space washer	Toleranzscheibe	FIB	V-0634F (a/b)
11	Contre-siège	Disc guide	Gegensitz	316	31052E
12	Porte-joint	Disc retainer	Dichtungsträger	FTG	V-5457/KC
13	Joint de siège	Disc	Dichtung	RBR	V-5467F (a/b)
13.1	Joint de siège (***)	Disc (***)	Dichtung (***)	PET	21268-01G (b***)
14	Axe	Stem	Stößel	303	57290
15	Siège	Seat	Sitz	316	31053C
16	Corps	Body	Gehäuse	FD4	(**)
17	Ressort	Spring	Feder	302	C-1533D
17.1	Ressort renforcé (PN25)	Spring heavy (PN25)	Verstärkte Feder (PN25)	302	C-1408J
20	Joint torique	O-ring	O-Ring	RBR	00752G (a/b)
23	Joint torique	O-ring	O-Ring	RBR	00836H
25	Bouchon	Plug	Stopfen	316	BGT4001
29	Rondelle plate	Washer	Unterlegscheibe	303	67753-04G

(**) Voir / See / Siehe HYT016F

(***) Recommandé si $\Delta P > 16$ bar / Recommended if $\Delta P > 16$ bar / Empfohlen wenn $\Delta P > 16$ bar

KC: Revêtement époxy / Standard epoxy coating / Epoxy-Pulverbeschichtung (minimum 250 μm)

KCO: KC + Visserie en acier inoxydable / Stainless steel bolts / Deckelschrauben aus Edelstahl

KCS: KC + Siège et contre-siège en acier inoxydable / Stainless steel seat and guide / Sitz und Gegensitz aus Edelstahl

KCOS: KCO + KCS.

► STD: STANDARD

PIECE DE RECHANGE / SPARE PARTS / ERSATZTEILE

KIT DE REPARATION / REPAIR KIT / REPARATURSATZ		
(a)	CLA-KIT HYTROL100-01 - GE 150/PN 10 - 16	91698-15
(b)	CLA-KIT HYTROL100-01 - GE 150/PN 25	 CLA-VAL

POS.	DESCRIPTION	DESCRIPTION	BESCHREIBUNG	MAT.	CLA-VAL Nr.
1	Bouchon-purgeur	Air release plug	Entlüftungstopfen	303	57576-02
2	Bouchon	Cover plug	Stopfen	316	BGT4001
3	Ecrou	Stud nut	Mutter	303	67811-08D
4	Goujon	Stud	Gewindebolzen	303	37048-02C
5	Palier de chapeau	Cover bearing	Deckellager	303	C-0974A
6	Chapeau	Cover	Deckel	FD4	57190-40
7	Ecrou d'axe	Stem nut	Stösselmutter	303	89379-01A
8	Rondelle de membrane	Diaphragm washer	Membranscheibe	FTG	V-5521/KC
9	Membrane	Diaphragm	Membrane	RBR	87893E (a)
9.1	Membrane (PN25)	Diaphragm (PN25)	Membrane (PN25)	RBR	C-6365F (b)
10	Cale d'épaisseur	Space washer	Toleranzscheibe	FIB	V-5138C (a/b)
11	Contre-siège	Disc guide	Gegensitz	316	C-7148E
12	Porte-joint	Disc retainer	Dichtungsträger	FTG	V-1672/KC
13	Joint de siège	Disc	Dichtung	RBR	V-1692C (a/b)
13.1	Joint de siège (***)	Disc (***)	Dichtung (***)	PET	21269-01E (b***)
14	Axe	Stem	Stössel	303	57291
15	Siège	Seat	Sitz	316	C-7150A
16	Corps	Body	Gehäuse	FD4	(**)
17	Ressort	Spring	Feder	302	C-1534B
17.1	Ressort renforcé (PN25)	Spring heavy (PN25)	Verstärkte Feder (PN25)	316	C-1409G
20	Joint torique	O-ring	O-Ring	RBR	00941F (a/b)
23	Joint torique	O-ring	O-Ring	RBR	00851G
25	Bouchon	Plug	Stopfen	316	BGT4001
29	Rondelle plate	Washer	Unterlegscheibe	303	67753-04G

(**) Voir / See / Siehe HYT016F

(***) Recommandé si $\Delta P > 16$ bar / Recommended if $\Delta P > 16$ bar / Empfohlen wenn $\Delta P > 16$ bar

KC: Revêtement époxy / Standard epoxy coating / Epoxy-Pulverbeschichtung (minimum 250 μm)

KCO: KC + Visserie en acier inoxydable / Stainless steel bolts / Deckelschrauben aus Edelstahl

KCS: KC + Siège et contre-siège en acier inoxydable / Stainless steel seat and guide / Sitz und Gegensitz aus Edelstahl

KCOS: KCO + KCS.

► STD: STANDARD

PIECE DE RECHANGE / SPARE PARTS / ERSATZTEILE

KIT DE REPARATION / REPAIR KIT / REPARATURSATZ		
(a)	CLA-KIT HYTROL100-01 - GE 200/PN 10 - 16	91698-30
(b)	CLA-KIT HYTROL100-01 - GE 200/PN 25	🔧 CLA-VAL

POS.	DESCRIPTION	DESCRIPTION	BESCHREIBUNG	MAT.	CLA-VAL Nr.
1	Bouchon-purgeur	Air release plug	Entlüftungstopfen	303	57576-02
2	Bouchon	Cover plug	Stopfen	316	BGT6001
3	Ecrou	Stud nut	Mutter	303	67811-08D
4	Goujon	Stud	Gewindebolzen	303	37048-02C
5	Palier de chapeau	Cover bearing	Deckellager	303	C-7414A
6	Chapeau	Cover	Deckel	FD4	57191-40
7	Ecrou d'axe	Stem nut	Stößelmutter	303	89380-01J
8	Rondelle de membrane	Diaphragm washer	Membranscheibe	FTG	V-1354/KC
9	Membrane	Diaphragm	Membrane	RBR	V-5125K (a)
9.1	Membrane (PN 25)	Diaphragm (PN 25)	Membrane (PN 25)	RBR	V-5571E (b)
10	Cale d'épaisseur	Space washer	Toleranzscheibe	FIB	V-5133D (a/b)
11	Contre-siège	Disc guide	Gegensitz	316	46698H
12	Porte-joint	Disc retainer	Dichtungsträger	FTG	V-1356/KC
13	Joint de siège	Disc	Dichtung	RBR	V-5566E (a/b)
13.1	Joint de siège (***)	Disc (***)	Dichtung (***)	PET	21270-01C (b***)
14	Axe	Stem	Stößel	303	V-1353B
15	Siège	Seat	Sitz	316	46699F
16	Corps	Body	Gehäuse	FD4	(**)
17	Ressort	Spring	Feder	302	C-7948H
20	Joint torique	O-ring	O-Ring	RBR	00758D (a/b)
22	Vis (8x)	Screw (8x)	Schraube (8x)	303	67972-25H
23	Joint torique	O-ring	O-Ring	RBR	00982K
25	Bouchon	Plug	Stopfen	316	BGT6001
29	Rondelle plate	Washer	Unterlegscheibe	303	67753-04G

(**) Voir / See / Siehe HYT016F

(***) Recommandé si $\Delta P > 16$ bar / Recommended if $\Delta P > 16$ bar / Empfohlen wenn $\Delta P > 16$ bar

KC: Revêtement époxy / Standard epoxy coating / Epoxy-Pulverbeschichtung (minimum 250 μ m)

KCO: KC + Visserie en acier inoxydable / Stainless steel bolts / Deckelschrauben aus Edelstahl

KCS: KC + Siège et contre-siège en acier inoxydable / Stainless steel seat and guide / Sitz und Gegensitz aus Edelstahl

KCOS: KCO + KCS.

► STD: STANDARD

PIECE DE RECHANGE / SPARE PARTS / ERSATZTEILE

KIT DE REPARATION / REPAIR KIT / REPARATURSATZ		
(a)	CLA-KIT HYTROL100-01 - GE 250/PN 10 - 16	91698-31
(b)	CLA-KIT HYTROL100-01 - GE 250/PN 25	🔧 CLA-VAL

POS.	DESCRIPTION	DESCRIPTION	BESCHREIBUNG	MAT.	CLA-VAL Nr.
1	Bouchon-purgeur	Air release plug	Entlüftungstopfen	303	57576-02
2	Bouchon	Cover plug	Stopfen	316	BGT6001
3	Ecrou	Stud nut	Mutter	SST	67814-08H
4	Goujon	Stud	Gewindebolzen	303	57621-08
5	Palier de chapeau	Cover bearing	Deckellager	303	C-8611A
6	Chapeau	Cover	Deckel	FD4	57192-40
7	Ecrou d'axe	Stem nut	Stößelmutter	303	25925-01H
8	Rondelle de membrane	Diaphragm washer	Membranscheibe	FTG	V-1778/KC
9	Membrane	Diaphragm	Membrane	RBR	V-5576D (a)
9.1	Membrane (PN 25)	Diaphragm (PN 25)	Membrane (PN 25)	RBR	1650301D (b)
10	Cale d'épaisseur	Space washer	Toleranzscheibe	FIB	V-5160G (a/b)
11	Contre-siège	Disc guide	Gegensitz	316	C-7957-01G
12	Porte-joint	Disc retainer	Dichtungsträger	FTG	V-1774/KC
13	Joint de siège	Disc	Dichtung	NBR	V-5569J (a/b)
13.1	Joint de siège (***)	Disc (***)	Dichtung (***)	PET	21271-01A (b***)
14	Axe	Stem	Stößel	303	V-1789G
15	Siège	Seat	Sitz	316	C-7958-01E
16	Corps	Body	Gehäuse	FD4	(*)
17	Ressort	Spring	Feder	SST	C-9113G
20	Joint torique	O-ring	O-Ring	RBR	00760K (a/b)
22	Vis (10x)	Screw (10x)	Schraube (10x)	303	67972-25H
23	Joint torique	O-ring	O-Ring	RBR	00865G
25	Bouchon	Plug	Stopfen	316	BGT6001
29	Rondelle plate	Washer	Unterlegscheibe	304	67754-04

(**) Voir / See / Siehe HYT016F

(***) Recommandé si $\Delta P > 16$ bar / Recommended if $\Delta P > 16$ bar / Empfohlen wenn $\Delta P > 16$ bar

KC: Revêtement époxy / Standard epoxy coating / Epoxy-Pulverbeschichtung (minimum 250 μ m)

KCO: KC + Visserie en acier inoxydable / Stainless steel bolts / Deckelschrauben aus Edelstahl

KCS: KC + Siège et contre-siège en acier inoxydable / Stainless steel seat and guide / Sitz und Gegensitz aus Edelstahl

KCOS: KCO + KCS.

► STD: STANDARD

PIECE DE RECHANGE / SPARE PARTS / ERSATZTEILE

KIT DE REPARATION / REPAIR KIT / REPARATURSATZ		
(a)	CLA-KIT HYTROL100-01 - GE 300/PN 10 - 16	91698-32
(b)	CLA-KIT HYTROL100-01 - GE 300/PN 25	🔧 CLA-VAL

POS.	DESCRIPTION	DESCRIPTION	BESCHREIBUNG	MAT.	CLA-VAL Nr.
1	Bouchon-purgeur	Air release plug	Entlüftungstopfen	303	57576-02
2	Bouchon	Cover plug	Stopfen	316	BGT6001
3	Ecrou	Stud nut	Mutter	303	67818-08J
4	Goujon	Stud	Gewindebolzen	303	V-6896-02A
5	Palier de chapeau	Cover bearing	Deckellager	303	C-8682B
6	Chapeau	Cover	Deckel	FD4	57193-40
7	Ecrou d'axe	Stem nut	Stößelmutter	303	25926-01F
8	Rondelle de membrane	Diaphragm washer	Membranscheibe	FTG	V5121/KC
9	Membrane	Diaphragm	Membrane	RBR	V-5544B (a)
9.1	Membrane (PN 25)	Diaphragm (PN 25)	Membrane (PN 25)	RBR	1649801G (b)
10	Cale d'épaisseur	Space washer	Toleranzscheibe	FIB	V-5131H (a/b)
11	Contre-siège	Disc guide	Gegensitz	316	46653C
12	Porte-joint	Disc retainer	Dichtungsträger	FTG	V-5012/KC
13	Joint de siège	Disc	Dichtung	RBR	V-5541H (a/b)
13.1	Joint de siège (***)	Disc (***)	Dichtung (***)	PET	21272-01J (b***)
14	Axe	Stem	Stößel	303	C-4047B
15	Siège	Seat	Sitz	316	46654A
16	Corps	Body	Gehäuse	FD4	(**)
17	Ressort	Spring	Feder	302	C-9516A
20	Joint torique	O-ring	O-Ring	RBR	00812J (a/b)
22	Vis (12x)	Screw (12x)	Schraube (12x)	303	67972-25H
23	Joint torique	O-ring	O-Ring	RBR	00869J
25	Bouchon	Plug	Stopfen	316	BGT6001
29	Rondelle plate	Washer	Unterlegscheibe	304	67756-04

(**) Voir / See / Siehe HYT016F

(***) Recommandé si $\Delta P > 16$ bar / Recommended if $\Delta P > 16$ bar / Empfohlen wenn $\Delta P > 16$ bar

KC: Revêtement époxy / Standard epoxy coating / Epoxy-Pulverbeschichtung (minimum 250 μ m)

KCO: KC + Visserie en acier inoxydable / Stainless steel bolts / Deckelschrauben aus Edelstahl

KCS: KC + Siège et contre-siège en acier inoxydable / Stainless steel seat and guide / Sitz und Gegensitz aus Edelstahl

KCOS: KCO + KCS.

► STD: STANDARD

PIECE DE RECHANGE / SPARE PARTS / ERSATZTEILE

KIT DE REPARATION / REPAIR KIT / REPARATURSATZ		
(a)	CLA-KIT HYTROL100-01 - GE 300/PN 10 - 16	91698-32
(b)	CLA-KIT HYTROL100-01 - GE 300/PN 25	🔧 CLA-VAL

POS.	DESCRIPTION	DESCRIPTION	BESCHREIBUNG	MAT.	CLA-VAL Nr.
1	Bouchon-purgeur	Air release plug	Entlüftungstopfen	303	57576-02
2	Bouchon	Cover plug	Stopfen	316	BGT6001
3	Ecrou	Stud nut	Mutter	303	67818-08J
4	Goujon	Stud	Gewindebolzen	303	V-6896-02A
5	Palier de chapeau	Cover bearing	Deckellager	303	C-8682B
6	Chapeau	Cover	Deckel	FD4	57193-40
7	Ecrou d'axe	Stem nut	Stößelmutter	303	25926-01F
8	Rondelle de membrane	Diaphragm washer	Membranscheibe	FTG	V-5121/KC
9	Membrane	Diaphragm	Membrane	RBR	V-5544B (a)
9.1	Membrane (PN 25)	Diaphragm (PN 25)	Membrane (PN 25)	RBR	1649801G (b)
10	Cale d'épaisseur	Space washer	Toleranzscheibe	FIB	V-5131H (a/b)
11	Contre-siège	Disc guide	Gegensitz	316	46653C
12	Porte-joint	Disc retainer	Dichtungsträger	FTG	V-5012/KC
13	Joint de siège	Disc	Dichtung	RBR	V-5541H (a/b)
13.1	Joint de siège (***)	Disc (***)	Dichtung (***)	PET	21272-01J (b***)
14	Axe	Stem	Stößel	303	C-4047B
15	Siège	Seat	Sitz	316	46654A
16	Corps	Body	Gehäuse	FD4	(**)
17	Ressort	Spring	Feder	302	C-9516A
20	Joint torique	O-ring	O-Ring	RBR	00812J (a/b)
22	Vis (12X)	Screw (12x)	Schraube (12x)	303	67972-25H
23	Joint torique	O-ring	O-Ring	RBR	00869J
25	Bouchon	Plug	Stopfen	316	BGT6001
29	Rondelle plate	Washer	Unterlegscheibe	304	67756-04

(**) Voir / See / Siehe HYT016F

(***) Recommandé si $\Delta P > 16$ bar / Recommended if $\Delta P > 16$ bar / Empfohlen wenn $\Delta P > 16$ bar

KC: Revêtement époxy / Standard epoxy coating / Epoxy-Pulverbeschichtung (minimum 250 μ m)

KCO: KC + Visserie en acier inoxydable / Stainless steel bolts / Deckelschrauben aus Edelstahl

KCS: KC + Siège et contre-siège en acier inoxydable / Stainless steel seat and guide / Sitz und Gegensitz aus Edelstahl

KCOS: KCO + KCS.

► STD: STANDARD

PIECE DE RECHANGE / SPARE PARTS / ERSATZTEILE

KIT DE REPARATION / REPAIR KIT / REPARATURSATZ		
(a)	CLA-KIT HYTROL100-01 - GE 300/PN 10 - 16	91698-32
(b)	CLA-KIT HYTROL100-01 - GE 300/PN 25	🔧 CLA-VAL

POS.	DESCRIPTION	DESCRIPTION	BESCHREIBUNG	MAT.	CLA-VAL Nr.
1	Bouchon-purgeur	Air release plug	Entlüftungstopfen	303	57576-02
2	Bouchon	Cover plug	Stopfen	316	BGT6001
3	Ecrou	Stud nut	Mutter	303	67818-08J
4	Goujon	Stud	Gewindebolzen	303	V-6896-02A
5	Palier de chapeau	Cover bearing	Deckellager	303	C-8682B
6	Chapeau	Cover	Deckel	FD4	57193-40
7	Ecrou d'axe	Stem nut	Stößelmutter	303	25926-01F
8	Rondelle de membrane	Diaphragm washer	Membranscheibe	FTG	V-5121/KC
9	Membrane	Diaphragm	Membrane	RBR	V-5544B (a)
9.1	Membrane (PN 25)	Diaphragm (PN 25)	Membrane (PN 25)	RBR	1649801G (b)
10	Cale d'épaisseur	Space washer	Toleranzscheibe	FIB	V-5131H (a/b)
11	Contre-siège	Disc guide	Gegensitz	316	46653C
12	Porte-joint	Disc retainer	Dichtungsträger	FTG	V-5012/KC
13	Joint de siège	Disc	Dichtung	RBR	V-5541H (a/b)
13.1	Joint de siège (***)	Disc (***)	Dichtung (***)	PET	21272-01J (b***)
14	Axe	Stem	Stößel	303	C-4047B
15	Siège	Seat	Sitz	316	46654A
16	Corps	Body	Gehäuse	FD4	(**)
17	Ressort	Spring	Feder	302	C-9516A
20	Joint torique	O-ring	O-Ring	RBR	00812J (a/b)
22	Vis (12x)	Screw (12x)	Schraube (12x)	303	67972-25H
23	Joint torique	O-ring	O-Ring	RBR	00869J
25	Bouchon	Plug	Stopfen	316	BGT6001
29	Rondelle plate	Washer	Unterlegscheibe	304	67756-04

(**) Voir / See / Siehe HYT016F

(***) Recommandé si $\Delta P > 16$ bar / Recommended if $\Delta P > 16$ bar / Empfohlen wenn $\Delta P > 16$ bar

KC: Revêtement époxy / Standard epoxy coating / Epoxy-Pulverbeschichtung (minimum 250 μ m)

KCO: KC + Visserie en acier inoxydable / Stainless steel bolts / Deckelschrauben aus Edelstahl

KCS: KC + Siège et contre-siège en acier inoxydable / Stainless steel seat and guide / Sitz und Gegensitz aus Edelstahl

KCOS: KCO + KCS.

► STD: STANDARD

PIECE DE RECHANGE / SPARE PARTS / ERSATZTEILE

KIT DE REPARATION / REPAIR KIT / REPARATURSATZ		
(a)	CLA-KIT HYTROL100-01 - GE 400/PN 10 - 16	91698-34
(b)	CLA-KIT HYTROL100-01 - GE 400/PN 25	🔧 CLA-VAL

POS.	DESCRIPTION	DESCRIPTION	BESCHREIBUNG	MAT.	CLA-VAL Nr.
1	Bouchon-purgeur	Air release plug	Entlüftungstopfen	303	57576-02
2	Bouchon	Cover plug	Stopfen	316	BGT6001
3	Ecrou	Stud nut	Mutter	303	67820-08E
4	Goujon	Stud	Gewindebolzen	303	37042-03D
5	Palier de chapeau	Cover bearing	Deckellager	303	57080
6	Chapeau	Cover	Deckel	FD4	57194-40
7	Ecrou d'axe	Stem nut	Stößelmutter	303	57091
8	Rondelle de membrane	Diaphragm washer	Membranscheibe	FTG	V-5588/KC
9	Membrane	Diaphragm	Membrane	RBR	V-5591C (a)
9.1	Membrane (PN 25)	Diaphragm (PN 25)	Membrane (PN 25)	RBR	23921-01J (b)
10	Cale d'épaisseur	Space washer	Toleranzscheibe	FIB	V-5601K (a/b)
11	Contre-siège	Disc guide	Gegensitz	316	43954-01F
12	Porte-joint	Disc retainer	Dichtungsträger	FTG	V-5594/KC
13	Joint de siège	Disc	Dichtung	RBR	V-1689J (a/b)
13.1	Joint de siège (***)	Disc (***)	Dichtung (***)	PET	V-1689J/KX (b***)
14	Axe	Stem	Stößel	303	32686J
15	Siège	Seat	Sitz	316	TV5596-01K
16	Corps	Body	Gehäuse	FD4	(**)
17	Ressort	Spring	Feder	302	30104E
18	Vis de palier (8x)	Screw (8x)	Schraube (8x)	SST	67605-07B
19	Joint de palier	Cover bearing gasket	Dichtung	RBR	00589C
20	Joint torique	O-ring	O-Ring	RBR	00876D
22	Vis (12x)	Screw (12x)	Schraube (12x)	303	67973-26D
21	Réduction supérieur	Pipe cap	Kappe	304	57008-01
23	Joint torique	O-ring	O-Ring	RBR	00999D
25	Bouchon	Plug	Stopfen	316	BGT6001
29	Rondelle plate	Washer	Unterlegscheibe	304	67757-04
30	Support guide	Housing cover bearing	Deckellagerhalterung	FD4	V-6700-01/KC

(**) Voir / See / Siehe HYT016F

(***) Recommandé si $\Delta P > 16$ bar / Recommended if $\Delta P > 16$ bar / Empfohlen wenn $\Delta P > 16$ bar

KC: Revêtement époxy / Standard epoxy coating / Epoxy-Pulverbeschichtung (minimum 250 μ m)

KCO: KC + Visserie en acier inoxydable / Stainless steel bolts / Deckelschrauben aus Edelstahl

KCS: KC + Siège et contre-siège en acier inoxydable / Stainless steel seat and guide / Sitz und Gegensitz aus Edelstahl

KCOS: KCO + KCS.

► STD: STANDARD

PIECE DE RECHANGE / SPARE PARTS / ERSATZTEILE

KIT DE REPARATION / REPAIR KIT / REPARATURSATZ		
(a)	CLA-KIT HYTROL100-01 - GE 400/PN 10 - 16	91698-34
(b)	CLA-KIT HYTROL100-01 - GE 400/PN 25	🔧 CLA-VAL

POS.	DESCRIPTION	DESCRIPTION	BESCHREIBUNG	MAT.	CLA-VAL Nr.
1	Bouchon-purgeur	Air release plug	Entlüftungstopfen	303	57576-02
2	Bouchon	Cover plug	Stopfen	316	BGT6001
3	Ecrou	Stud nut	Mutter	303	67820-08E
4	Goujon	Stud	Gewindebolzen	303	37042-03D
5	Palier de chapeau	Cover bearing	Deckellager	303	57080
6	Chapeau	Cover	Deckel	FD4	57194-40
7	Ecrou d'axe	Stem nut	Stößelmutter	303	57091
8	Rondelle de membrane	Diaphragm washer	Membranscheibe	FTG	V-5588/KC
9	Membrane	Diaphragm	Membrane	RBR	V-5591C (a)
9.1	Membrane (PN 25)	Diaphragm (PN 25)	Membrane (PN 25)	RBR	23921-01J (b)
10	Cale d'épaisseur	Space washer	Toleranzscheibe	FIB	V-5601K (a/b)
11	Contre-siège	Disc guide	Gegensitz	316	43954-01F
12	Porte-joint	Disc retainer	Dichtungsträger	FTG	V-5594/KC
13	Joint de siège	Disc	Dichtung	RBR	V-1689J (a/b)
13.1	Joint de siège (***)	Disc (***)	Dichtung (***)	PET	V-1689J/KX (b***)
14	Axe	Stem	Stößel	303	32686J
15	Siège	Seat	Sitz	316	TV5596-01K
16	Corps	Body	Gehäuse	FD4	(**)
17	Ressort	Spring	Feder	302	30104E
18	Vis de palier (8x)	Screw (8x)	Schraube (8x)	SST	67605-07B
19	Joint de palier	Cover bearing gasket	Dichtung	RBR	00589C
20	Joint torique	O-ring	O-Ring	RBR	00876D
22	Vis (12x)	Screw (12x)	Schraube (12x)	303	67973-26D
21	Réduction supérieur	Pipe cap	Kappe	304	57008-01
23	Joint torique	O-ring	O-Ring	RBR	00999D
25	Bouchon	Plug	Stopfen	316	BGT6001
29	Rondelle plate	Washer	Unterlegscheibe	304	67757-04
30	Support guide	Housing cover bearing	Deckellagerhalterung	FD4	V-6700-01/KC

(**) Voir / See / Siehe HYT016F

(***) Recommandé si $\Delta P > 16$ bar / Recommended if $\Delta P > 16$ bar / Empfohlen wenn $\Delta P > 16$ bar

KC: Revêtement époxy / Standard epoxy coating / Epoxy-Pulverbeschichtung (minimum 250 μ m)

KCO: KC + Visserie en acier inoxydable / Stainless steel bolts / Deckelschrauben aus Edelstahl

KCS: KC + Siège et contre-siège en acier inoxydable / Stainless steel seat and guide / Sitz und Gegensitz aus Edelstahl

KCOS: KCO + KCS.

PILOTE DE REDUCTION DE PRESSION

Le pilote de réduction de pression est du type normalement ouvert, à action indirecte.

Une augmentation de la pression de sortie tend à fermer le pilote, au contraire une diminution de la pression de sortie tend à l'ouvrir.

Réglage : visser la vis de réglage (2) pour augmenter la pression de sortie.

PRESSURE REDUCING CONTROL

The pressure reducing control is a "normally open" control. An increase in outlet pressure tends to close the pressure reducing control, and a decrease in outlet pressure tends to open it.

Adjustment : turn the adjusting screw (2) clockwise to increase the outlet pressure.

DRUCKREDUZIERVENTIL

Das Druckreduzier-Steuerventil ist eine sogenannte "Auf-Kontrolle" welche die Schwankungen des sekundären Druckes am Ausgang des Hauptventils misst. Eine Erhöhung des Druckes bewirkt die Schließung des Steuerventils; eine Druckminderung hingegen bewirkt seine Öffnung.

Einstellung : Regulierschraube (2) im Uhrzeigersinn drehen um den Ausgangsdruck zu erhöhen.

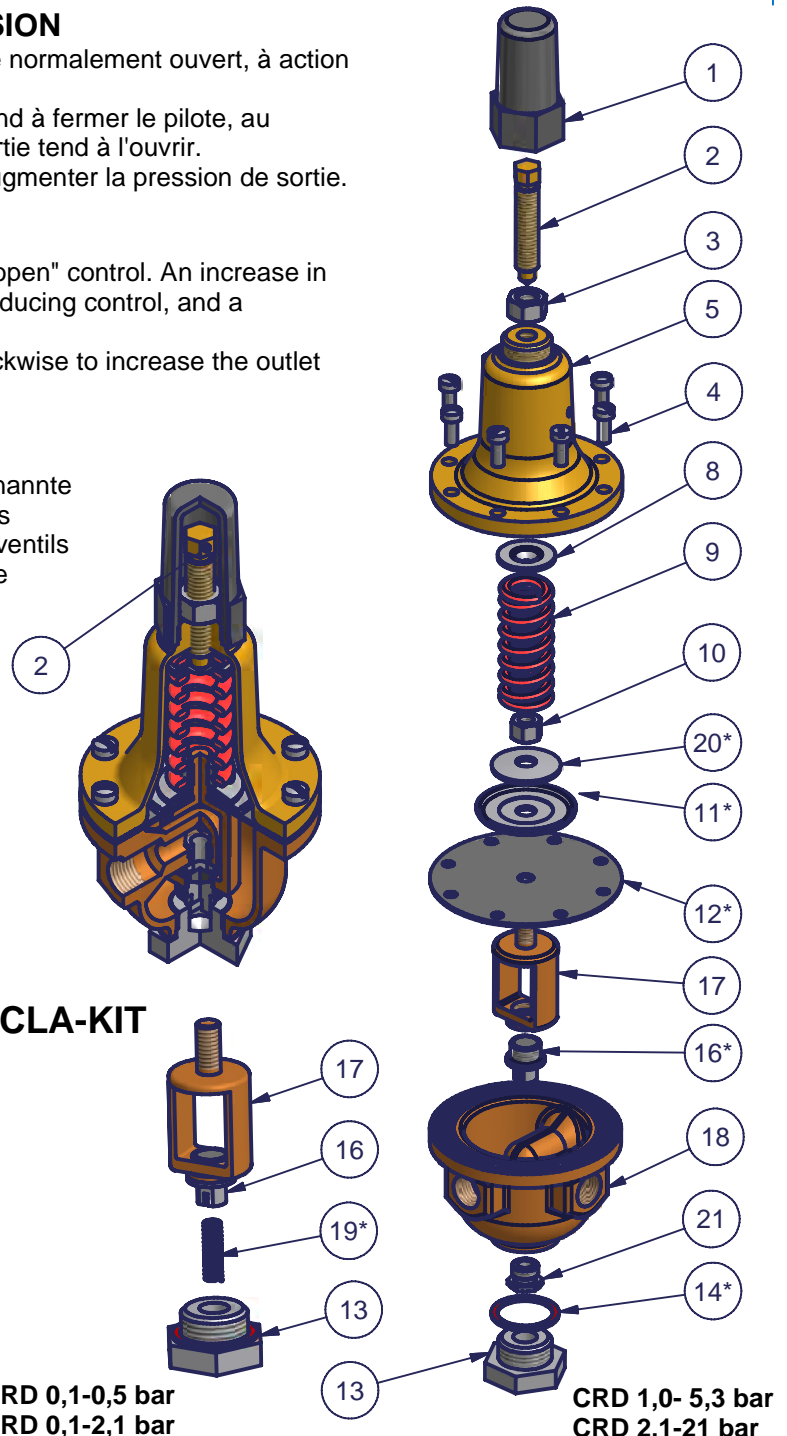
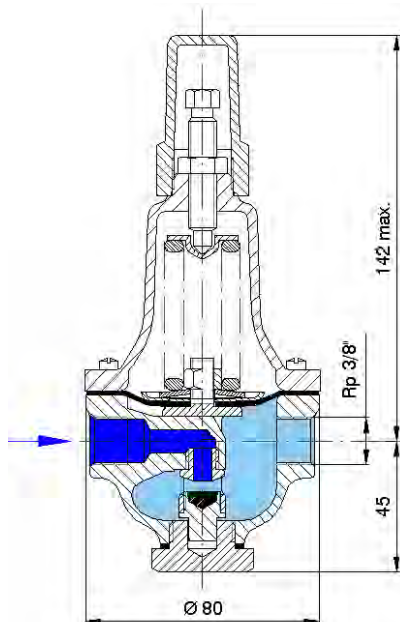

Domaine de réglage
Adjustement ranges
Einstellung

0,1-0,5 bar
0,1-2,1 bar
1,0-5,3 bar
1,4-7,2 bar
2,1-21,0 bar



0,04 bar
0,2 bar
0,6 bar
1,0 bar
1,9 bar

● Information

- ✓ CRD STANDARD
- ✓ CRD/WWS
- ✓ CRD/IND
- ✓ CRD/OFS
- ✓ CRD/SWS
- ✓ CRD/AF

CRD001LT
CRD003LT
CRD004LT
CRD005LT
CRD002LT
CRD801LT

► STD: Standard

PIECE DE RECHANGE / SPARE PARTS / ERSATZTEILE

KIT DE REPARATION / REPAIR KIT / REPARATURSATZ		
(a)	CLA-KIT CRD (0,1 - 0,5 / 0,1 - 2,1 bar)	*CKCRD-STD-01
(b)	CLA-KIT CRD (1,0 - 5,3 / 2,1 - 21,0 bar)	*CKCRD-STD-02

POS.	DESCRIPTION	DESCRIPTION	BESCHREIBUNG	MAT.	CLA-VAL Nr.
1	Capuchon	Cap	Schutzkappe	PLA	67628J
2	Vis de réglage	Adjusting screw	Regulierschraube	LTO	71882-01D
3	Ecrou de blocage	Jam nut	Sicherungsmutter	303	67801-06J
4	Vis (8x)	Screw (8x)	Schraube (8x)	SST	67578-21B
5	Couvercle	Cover	Ventildeckel	LTO	C-2544K
8	Guide ressort	Spring guide	Federführung	302	71881H
9	Ressort	Spring	Feder		
9.1	0,1 - 0,5 bar (bleu)	0,1 - 0,5 bar (blue)	0,1 - 0,5 bar (blau)	302	82575C
9.2	0,1 - 2,1 bar (acier)	0,1 - 2,1 bar (steel)	0,1 - 2,1 bar (Stahl)	SST	81594E
9.3	0,1 - 5,3 bar (rouge)	0,1 - 5,3 bar (red)	0,1 - 5,3 bar (rot)	SST	71884B
9.4	1,4 - 7,2 bar (acier)	1,4 - 7,2 bar (steel)	1,4 - 7,2 bar (Stahl)	316	206321-01E
9.5	2,1 - 21,0 bar (vert)	2,1 - 21,0 bar (green)	2,1 - 21,0 bar (grün)	SST	71885J
10	Ecrou	Nut	Mutter	303	71883D
11	Rondelle de membrane	Diaphragm washer	Membranscheibe	302	71891G (a/b)
12	Membrane	Diaphragm	Membrane	RBR	C-1505B (a/b)
13	Bouchon	Plug, body	Zapfen	303	57153
14	Joint	Gasket	Dichtung	FIB	40174F (a/b)
15	Bouchon	Plug	Zapfen	316	BGT2001
16	Joint de siège 0,1 - 2,1 bar	Disc retainer assembly 0,1 - 2,1 bar	Sitzdichtung 0,1 - 2,1 bar	303	57996-11 (a)
16.1	Joint de siège 1,0 - 21 bar	Disc retainer assembly 1,0 - 21 bar	Sitzdichtung 1,0 - 21 bar	303	57996-01 (b)
17	Etrier	Yoke	Tragbügel	BRZ	V-6951H
17.1	Etrier (PN 25)	Yoke (PN 25)	Tragbügel (PN 25)	316	87125B
18	Corps 3/8"	Body 3/8"	Gehäuse 3/8"	BRZ	22205-01H
19	Ressort 0,1 - 2,1 bar	Spring 0,1 - 2,1 bar	Feder 0,1 - 2,1 bar	302	V-0558G (a)
20	Rondelle Belleville	Belleville washer	Belleville Scheibe	STL	70550-07E (a/b)
21	Siège	Seat	Sitz	316	83396-03G

TYPE CRD/STD	CLA-VAL Nr.	
0,1 - 0,5 bar	SOL090-001	
0,1 - 2,1 bar	SOL090-002	
1,0 - 5,3 bar	SOL090-003	
1,4 - 7,2 bar	SOL090-010	
2,1 - 21,0 bar	SOL090-006	Standard PN 10 - 16
CRD/KX 2,1 - 21,0 bar	SOL090-005	Standard PN 25



► Installation - Operation - Maintenance

► DESCRIPTION

The CRD Pressure Reducing Control automatically reduces a higher inlet pressure to a lower outlet pressure. It is a direct acting, spring loaded, diaphragm type control that operates hydraulically or pneumatically. It may be used as a self-contained valve or as a pilot control for a CLA-VAL main valve. It will hold a constant downstream pressure within very close pressure limits.

► OPERATION

The CRD Pressure Reducing Control is normally held open by the force of the compression spring above the diaphragm; and delivery pressure acts on the underside of the diaphragm. Flow through the valve responds to changes in downstream demand to maintain a pressure.

► INSTALLATION

The CRD Pressure Reducing Control may be installed in any position. There is one inlet port and two outlets, for either straight or angle installation. The second outlet port can be used for a gage connection. A flow arrow is marked on the body casting.

► ADJUSTMENT PROCEDURE

The CRD Pressure Reducing Control can be adjusted to provide a delivery pressure range as specified on the nameplate. Pressure adjustment is made by turning the adjustment screw to vary the spring pressure on the diaphragm. The greater the compression on the spring the higher the pressure setting.

- 1- Turn the adjustment screw in (clockwise) to increase delivery pressure.
- 2- Turn the adjustment screw out (counter-clockwise) to decrease the delivery pressure.
- 3- When pressure adjustment is completed tighten jam nut on adjusting screw and replace protective cap.
- 4- When this control is used, as a pilot control on a CLA-VAL main valve, the adjustment should be made under flowing conditions. The flow rate is not critical, but generally should be somewhat lower than normal in order to provide an inlet pressure several psi higher than the desired setting.

The approximate minimum flow rates given in the table are for the main valve on which the CRD is installed.

Valve Size	1 1/4" -3"	4"-8"	10"-16"
Minimum Flow l/s	0,95 - 1,9	3,15 - 12,6	19,0 - 41,0

► MAINTENANCE

DISASSEMBLY

To disassemble follow the sequence of the item numbers assigned to parts in the sectional illustration (CRD001TT).

REASSEMBLY

Reassembly is the reverse of disassembly. Caution must be taken to avoid having the yoke (17) drag on the inlet nozzle of the body (18).

Follow this procedure:

- 1- Place yoke (17) in body and screw the disc retainer assembly (16) until it bottoms.
- 2- Install gasket (14) and spring (19) for 2-30 and 2-6.5 psi range onto plug (13) and fasten into body. Disc retainer must enter guide hole in plug as it is assembled. Screw the plug in by hand. Use wrench to tighten only.
- 3- Place diaphragm (12) diaphragm washer (11) and Belleville washer (20) on yoke. Screw on hex nut (10).
- 4- Hold the diaphragm so that the screw holes in the diaphragm and body align. Tighten diaphragm nut with a wrench. At the final tightening release the diaphragm and permit it to rotate 5° to 10°. The diaphragm holes should now be properly aligned with the body holes.

To check for proper alignment proceed as follows:

Rotate diaphragm clockwise and counter clockwise as far as possible. Diaphragm screw holes should rotate equal distance on either side of body screw holes ±1/8".

Repeat assembly procedure until diaphragm and yoke are properly aligned. There must be no contact between yoke and body nozzle during its normal movement. To simulate this movement hold body and diaphragm holes aligned. Move yoke to open and closed positions. There must be no evidence of contact or dragging.

- 5- Install spring (9) with spring guide (8).
- 6- Install cover (5), adjusting screw (2) and nut (3), then cap (1).

SYMPTOM	PROBABLE CAUSE	REMEDY
Fails to open when deliver pressure lowers	No spring compression	Tighten adjusting screw
	Damaged spring	Disassemble and replace
	Spring guide (8) is not in place	Assemble properly
	Yoke dragging on inlet nozzle	Disassemble and reassemble properly (refer to Reassembly)
Fails to close when delivery pressure rises	Spring compressed solid	Back off adjusting screw
	Mechanical obstruction	Disassemble and reassemble properly (refer to Reassembly)
	Worn disc	Disassemble remove and replace disc retainer assembly
	Yoke dragging on inlet nozzle	Disassemble and reassemble properly (refer to Reassembly)
Leakage from cover vent hole	Damaged diaphragm	Disassemble and replace
	Loose diaphragm nut	Remove cover and tighten nut

PILOTE DE MAINTIEN DE PRESSION

Le pilote de maintien de pression est du type normalement fermé à action directe.

Le pilote mesure la pression d'un réseau protégé par l'intermédiaire d'une tubulure de mesure de pression à distance. Une augmentation de la pression du réseau protégé tend à ouvrir le pilote, au contraire une diminution de la pression du réseau protégé tend à le fermer.

Réglage : visser la vis de réglage (9) pour augmenter la pression du réseau protégé.

PRESSURE RELIEF CONTROL

The pressure relief control is a direct acting, spring loaded, diaphragm type relief pilot. The pressure relief control is a normally closed control. When the controlling pressure exceeds the spring setting, the control opens. When the controlling pressure drops below spring setting, the spring returns the control to its normally closed position.

Adjustment : turn the adjusting screw (9) clockwise to increase pressure setting.

DRUCKHALTESTEUERVENTIL

Das Druckhaltesteuerventil ist eine sogenannte "Zu-Kontrolle". Es misst den Druck des Netzes über den Anschluss einer Ferndruckleitung. Eine Druckerhöhung des geschützten Netzes bewirkt die Öffnung des Steuerventils; eine Druckminderung hingegen bewirkt seine Schliessung.

Einstellung : Regulierschraube (9) im Uhrzeigersinn drehen um den Sicherheitsdruck im geschützten Netz zu erhöhen.

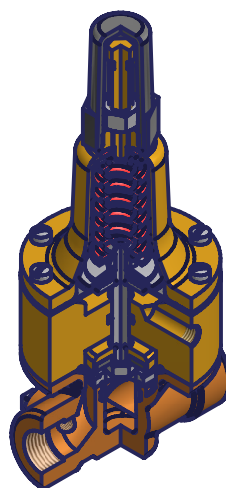
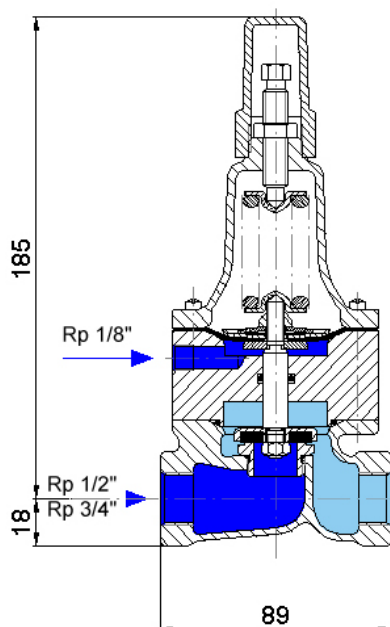

* = CLA-KIT

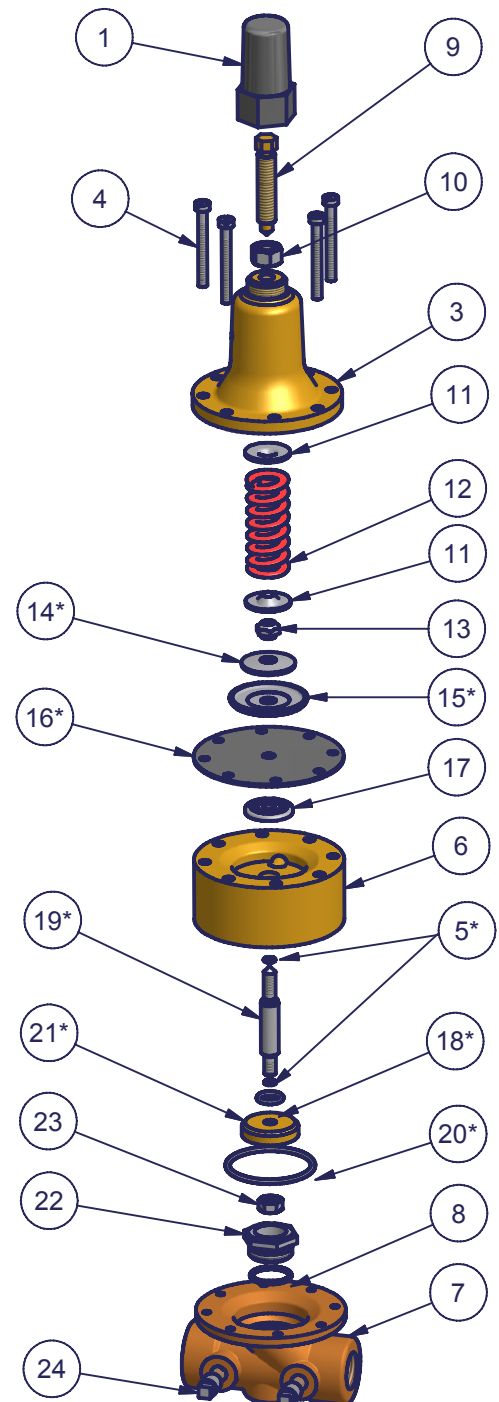

Domaine de réglage
Adjustment ranges
Einstellung

0,1 - 2,1 bar
0,1 - 5,3 bar
1,4 - 14,0 bar
7,0 - 21,0 bar



0,2 bar
0,6 bar
2,0 bar
1,3 bar

● Information

✓ CRL STANDARD	CRL001LT
✓ CRL/WWS	CRL003LT
✓ CRL/IND	CRL004LT
✓ CRL/OFS	CRL005LT
✓ CRL/SWS	CRL002LT
✓ CRL/AF	CRL801LT

► STD: Standard

PIECE DE RECHANGE / SPARE PARTS / ERSATZTEILE

KIT DE REPARATION / REPAIR KIT / REPARATURSATZ		
(a)	CLA-KIT CRL Standard	*CKCRL-STD-01

POS.	DESCRIPTION	DESCRIPTION	BESCHREIBUNG	MAT.	CLA-VAL Nr.
1	Capuchon	Cap	Schutzkappe	PLA	67628J
3	Couvercle	Cover	Ventildeckel	LTO	C-2544K
4	Vis (8x)	Screw (8x)	Schraube (8x)	SST	67578-67E
5	Joint torique (2x)	O-ring (2x)	O-Ring (2x)	RBR	00902H (a)
6	Corps intermédiaire	Power unit body	Zwischen-Gehäuse	LTO	57019-03
7.1	Corps 1/2"	Body 1/2"	Gehäuse 1/2"	BRZ	57020
7.2	Corps 3/4"	Body 3/4"	Gehäuse 3/4"	BRZ	57282
8	Joint torique	O-ring	O-Ring	RBR	00718H
9	Vis de réglage	Adjusting screw	Regulierschraube	LTO	71882-01D
10	Ecrou 3/8"-16 UNC	Jam nut	Sicherungsmutter	303	67801-06J
11	Guide ressort (2x)	Spring guide (2x)	Sicherungsmutter	302	71881H
12	Ressort	Spring	Feder		
12.1	1,4 - 14,0 bar (vert)	1,4 - 14,0 bar (green)	1,4 - 14,0 bar (grün)	SST	71885J
12.2	0,1 - 5,3 bar (rouge)	0,1 - 5,3 bar (red)	0,1 - 5,3 bar (rot)	SST	71884B
12.3	0,1 - 2,1 bar (acier)	0,1 - 2,1 bar (steel)	0,1 - 2,1 bar (Stahl)	SST	81594E
13	Ecrou	Nut	Mutter	LTO	73034B
14	Rondelle Belleville	Belleville washer	Belleville Scheibe	STL	70550-07E (a)
15	Rondelle de membrane supérieure	Upper diaphragm washer	Obere Membranscheibe	302	71891G (a)
16	Membrane	Diaphragm	Membrane	RBR	C-1505B (a)
17	Rondelle de membrane inférieure	Lower diaphragm washer	Untere Membranscheibe	303	45871B
18	Joint torique	O-ring	O-Ring	RBR	00746J (a)
19	Axe	Stem	Stößel	303	89824-01F (a)
20	Joint torique	O-ring	O-Ring	RBR	00767E (a)
21	Joint de siège	Disc retainer assembly	Dichtungsträger	LN	C-8964D (a)
22	Siège	Seat	Sitz	303	62187A
23	Ecrou	Nut	Mutter	303	67798-06G
24	Bouchon (2x)	Plug (2x)	Zapfen (2x)	316	BGT0001

TYPE CRL/STD	CLA-VAL Nr.	
0,1 - 2,1 bar	SOL050-006	1/2"
0,1 - 5,3 bar	SOL050-001	1/2"
1,4 - 14,0 bar	SOL050-002	1/2"
0,1 - 2,1 bar	-	3/4"
0,1 - 5,3 bar	SOL050-031	3/4"
1,4 - 14,0 bar	79229-02H	3/4"



CLA-VAL CRL - 55F - 55L

Pressure Relief Control

► Installation - Operation - Maintenance

► DESCRIPTION

The Pressure Relief Control is a direct acting, spring loaded, diaphragm type relief valve. It may be used as a self-contained valve or as a pilot control for a CLA-VAL main valve. It opens and closes within very close pressure limits.

► OPERATION

The Pressure Relief Control is normally held closed by the force of the compression spring above the diaphragm; control pressure is applied under the diaphragm. When the controlling pressure exceeds the spring setting, the disc is lifted off its seat, permitting flow through the control. When controlling pressure drops below spring setting, the spring returns the control to its normally closed position.

► INSTALLATION

The Pressure Relief Control may be installed in any position. The control body (7) has one inlet and one outlet port with a side pipe plug (24) at each port. These plugs are used for control connections or gauge applications. The inlet in the power unit body (6) is the sensing line port. A flow arrow is marked on the body casting.

► ADJUSTMENT PROCEDURE

The Pressure Relief Control can be adjusted to provide a relief setting at any point within the range found on the name-plate. Pressure adjustment is made by turning the adjustment screw (9) to vary the spring pressure on the diaphragm. Turning the adjustment screw clockwise increases the pressure required to open the valve. Counter clockwise decreases the pressure required to open the valve. When pressure adjustments are complete the jam nut (10) should be tightened and the protective cap (1) replaced. If there is a problem of tampering, lock wire holes have been provided in cap and cover. Wire the cap to cover and secure with lead seal.

► MAINTENANCE

DISASSEMBLY

The Pressure Relief Control does not need to be removed from the line for disassembly. Make sure that pressure shut down is accompanied prior to disassembly. If the Pressure Relief Control is removed from the line for disassembly be sure to use a soft jawed vise to hold body during work.

Refer to Parts List Drawing for Item Numbers (CRL001TT).

- 1- Remove cap (1), loosen jam nut (10) and turn adjusting screw counter clockwise until spring tension is relieved.
- 2- Remove the eight screws (4) holding the cover (3) and power unit body (6). Hold the cover and power unit together and place on a suitable work surface. See NOTE under REASSEMBLY.
- 3- Remove the cover (3) from power unit body (6). The spring (12) and two spring guides (11).
- 4- Remove nut (13) from stem (19) and slide off the Belleville washer (14), the upper diaphragm washer (15) and the diaphragm (16).
- 5- Pull the stem (19) with the disc retainer assembly (21) through the bottom of power unit. The lower diaphragm washer (17) will slide off of stem top.
- 6- Remove jam nut (23) and disc retainer assembly (21) from stem. Use soft jawed pliers or vise to hold stem. The polished surface of stem must not be scored or scratched.

- 7- The seat (22) need not be removed unless it is damaged. If removal is necessary use proper size socket wrench and turn counter clockwise.

Note: Some models have an integral seat in the body (7).

INSPECTION

Inspect all parts for damage, or evidence of cross threading. Check diaphragm and disc retainer assembly for tears, abrasions or other damage. Check all metal parts for damage, corrosion or excessive wear.

REPAIR AND REPLACEMENT

Minor nicks and scratches may be polished out using 400 grit wet or dry sandpaper fine emery or crocus cloth. Replace all o-rings and any damaged parts. When ordering replacement parts, be sure to specify parts list item number and all nameplate data.

REASSEMBLY

In general, reassembly is the reverse of disassembly. However, the following steps should be observed:

- 1- Lubricate the o-Ring (18) with a small amount of a good grade of waterproof grease, (Dow Corning 44 medium grade or equal). Use grease sparingly and install o-ring in power unit body (6).
- 2- Install stem (19) in power unit body (6). Use a rotating motion with minimum pressure to let stem pass through o-ring.
Do not cut o-ring!
- 3- Install o-ring (5) at top of stem (19). Place lower diaphragm washer (17) on the stem with the serrated side up. Position diaphragm (16), upper diaphragm washer (15), with serration down, and Belleville washer (14) with concave side down.
- 4- Position power unit body (6) as shown on parts list drawing (top view).
- 5- Continue reassembly as outlined in disassembly steps 1- through 3-.

Note: Item (4) Screw will have a quantity of 8x for the 0-75 and 20-200 psi design and a quantity of 4x for the 100-300psi design. Item (25) Screw is used on the 100-300psi design only. Install item (25), before item (4) for preload of item (12) spring.

SYMPTOM	PROBABLE CAUSE	REMEDY
Fails to open	Controlling pressure too low	Back off adjusting screw until valve opens
Fails to open with spring compression removed	Mechanical obstruction, corrosion, scale build-up on stem	Disassemble, locate and remove obstruction, scale
Leakage from cover vent hole when controlling pressure is applied	Diaphragm damage	Disassembly replace damaged diaphragm
	Loose diaphragm assembly	Tighten upper diaphragm washer
Fails to close	No spring compression	Reset pressure adjustment
Fails to close with spring compressed	Mechanical obstruction	Disassemble, locate and remove obstruction

ROBINET A POINTEAU

Le robinet à poiteau à action unidirectionnelle permet de régler la vitesse d'ouverture de la vanne de base.

Réglage : visser le poiteau (8) dans le sens horaire pour diminuer le passage.

FLOW CONTROL COCK

Flow control cock regulates the opening speed of main valve.

Adjustment : turn the adjusting stem (8) clockwise to increase restriction.

EIN-WEG NADELVENTIL

Das Einweg Nadelventil ermöglicht die Oeffnungsgeschwindigkeit des Hauptventils zu regulieren.

Einstellung : Nadelschraube (8) im Uhrzeigersinn drehen um Strömung zu beschränken.

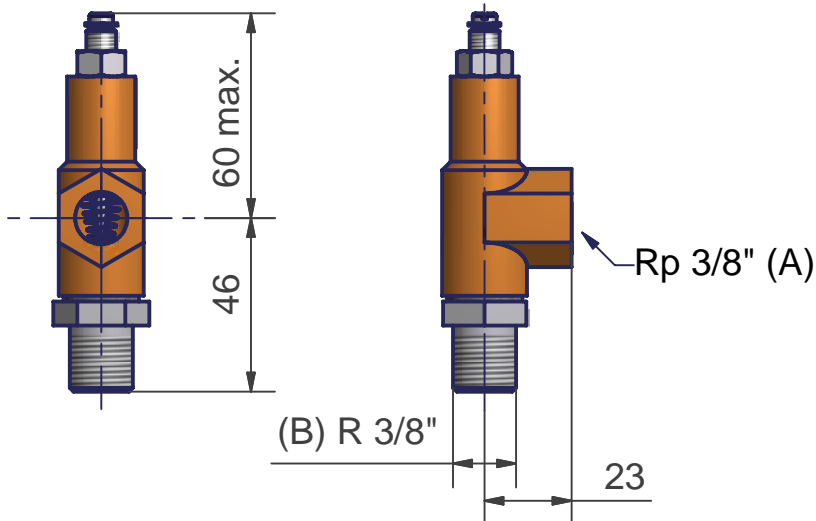
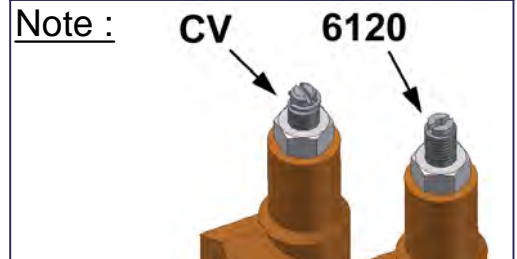

Ecoulement contrôlé
Restricted flow
Beschränkte
Strömung

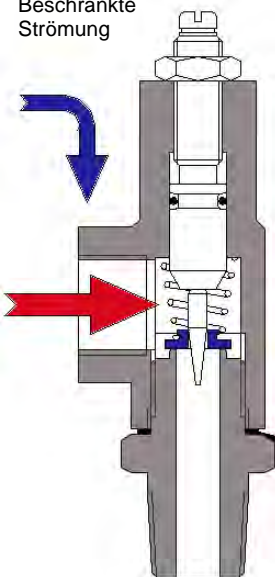

Ecoulement libre
Free flow
Frei Strömung

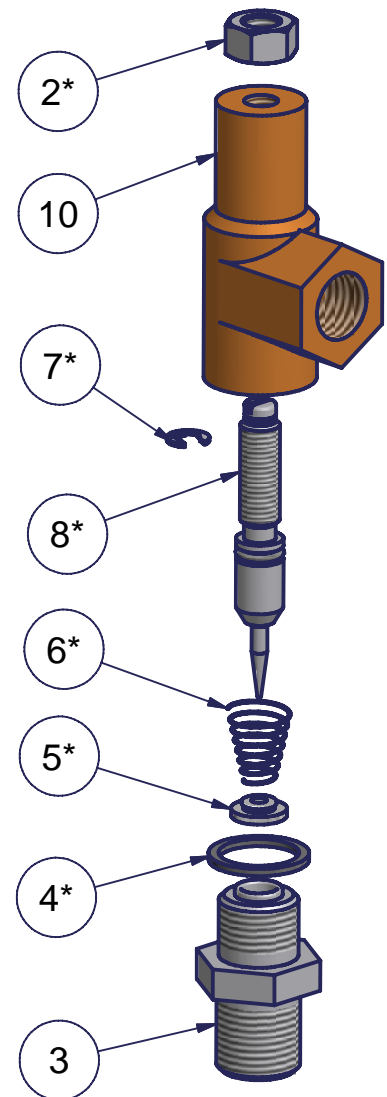
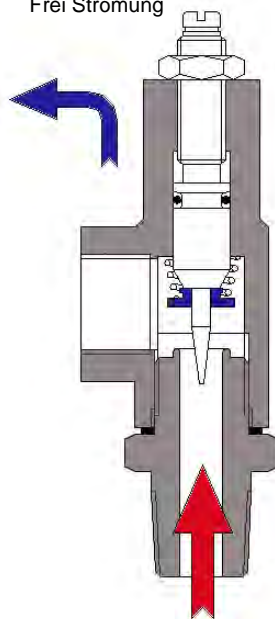

● Information

✓ CV STANDARD	CV0001LT
✓ CV/WWS	CV0003LT
✓ CV/IND	CV0004LT
✓ CV/OFS	CV0005LT
✓ CV/SWS	CV0002LT
✓ CV/AF	CV0008LT



► STD: Standard

PIECE DE RECHANGE / SPARE PARTS / ERSATZTEILE

KIT DE REPARATION / REPAIR KIT / REPARATURSATZ		
(a)	CLA-KIT CV Standard	*CKCV-STD-01

POS.	DESCRIPTION	DESCRIPTION	BESCHREIBUNG	MAT.	CLA-VAL Nr.
2	Ecrou	Nut	Mutter	303	67800-06A (a)
3	Siège	Seat	Sitz	303	57482
4	Joint	Gasket	Dichtung	FIB	30022J (a)
5	Clapet	Disc	Dichtungsring	MO4	C-2921K (a)
6	Ressort	Spring	Feder	302	C-2924D (a)
7	Clip	Ring retainer	Übersteckring	SST	68133-02K (a)
8	Pointeau	Stem	Nadelstößel	303	97010-01B (a)
9	Joint torique	O-ring	O-Ring	VIT	00927E (a)
10	Corps CV 3/8"	Housing CV 3/8"	Gehäuse CV 3/8"	BRZ	57644

TYPE CV/STD	CLA-VAL Nr.
CV	97015-01A



► Installation - Operation - Maintenance

► DESCRIPTION

The CLA-VAL Model CV Flow Control is a simply-designed, spring-loaded check valve. Rate of flow is full flow in one direction and restricted in other direction. Flow is adjustable in the restricted direction. It is intended for use in conjunction with a pilot control system on a CLA-VAL Automatic Control Valve.

► OPERATION

The CV Flow Control permits full flow from port A to B, and restricted flow in the reverse direction. Flow from port A to B lifts the disc from seat, permitting full flow. Flow in the reverse direction seats the disc, causing fluid to pass through the clearance between the stem and the disc. This clearance can be increased, thereby increasing the restricted flow, by screwing the stem out, or counter-clockwise. Turning the stem in, or clockwise reduces the clearance between the stem and the disc, thereby reducing the restricted flow.

► INSTALLATION

Install the CV Flow Control as shown in the valve schematic. All connections must be tight to prevent leakage.

► MAINTENANCE

DISASSEMBLY

Follow the sequence of the item numbers assigned to the parts in the cross sectional illustration for recommended order of disassembly (see page CV001TT).

INSPECTION

Inspect all threads for damage or evidence of cross-threading. Check mating surface of seat and valve disc for excessive scoring or embedded foreign particles. Check spring for visible distortion, cracks and breaks. Inspect all parts for damage, corrosion and cleanliness.

CLEANING

After disassembly and inspection, cleaning of the parts can begin. Water service usually will produce mineral or lime deposits on metal parts in contact with water. If the deposit is not removed after cleaning, then a fine grit (400) wet or dry sandpaper can be used with water. Rinse parts in water before handling.

Dry with compressed air or a clean, lint-free cloth. Protect from damage and dust until reassembled.

REPAIR AND REPLACEMENT

Minor nicks and scratches may be polished out using a fine grade of emery or crocus cloth; replace parts if scratches cannot be removed. Replace o-ring packing and gasket each time CV Flow Control is overhauled (see replace packing in the spare parts list). Replace all parts which are defective. Replace any parts which create the slightest doubt that they will not afford completely satisfactory operation. Use Inspection steps as a guide.

REASSEMBLY

Reassembly is the reverse of disassembly; no special tools are required.

TEST PROCEDURE

No testing of the flow Control is required prior to reassembly to the pilot control system on CLA-VAL Main Valve.

FILTRE A BUSE INCORPOREE

Ce filtre empêche tout corps étranger d'entrer dans le circuit d'asservissement. Il est recommandé de nettoyer périodiquement la cartouche du filtre. La vitesse de réaction de la vanne est liée au diamètre de la buse. Plus la diamètre est petit, plus la vanne réagit rapidement. Au contraire, pour un grand diamètre de buse la vanne va réagir lentement.

STRAINER AND ORIFICE ASSEMBLY

The strainer is installed in the pilot supply line to protect the pilot system from foreign particles. The strainer screen must be cleaned periodically. Speed reaction of the valve and orifice plug are directly connected. The valve will react quickly with a small orifice and on the contrary slowly with a big orifice.

FILTER MIT EINGEBAUTER DÜSE

Der Filter verhindert das Eindringen von Fremdkörpern ins Steuersystem. Das Sieb des Filters muss von Zeit zu Zeit gereinigt werden. Die Geschwindigkeitsreaktion des Ventils hängt mit der Düse zusammen. Je kleiner die Düse ist, je schneller wird das Ventil reagieren.

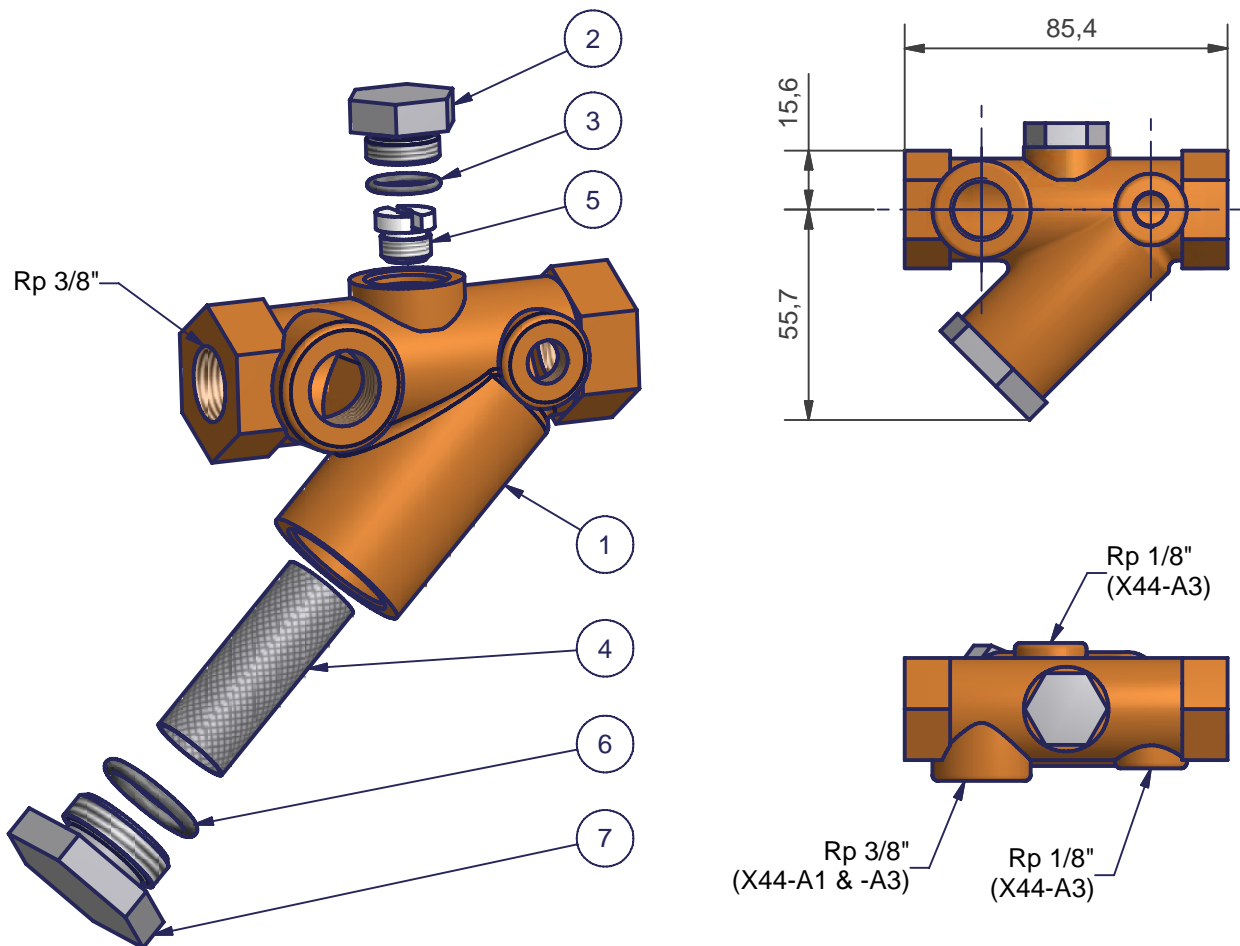

X44-A1 : 1 x Rp 3/8"

X44-A3 : 1 x Rp 3/8"
2 x Rp 1/8"

● Information

✓ X44A Standard	X44001LT
✓ X44A/SWS	X44002LT
✓ X44A/WWS	X44003LT
✓ X44A/IND	X44004LT
✓ X44A/OFS	X44005LT
✓ X44A/AF	X44006LT



CLA-VAL X44-A

Filtre - Strainer - Filter X44-A1 & X44-A3

PN 10 - 16 - 25

► STD: Standard

PIECE DE RECHANGE / SPARE PARTS / ERSATZTEILE

KIT DE REPARATION / REPAIR KIT / REPARATURSATZ		
(a)	CLA-KIT X44A Standard (Cartouche, Screen, Sieb 0,2)	*CKX44-STD-01
(b)	CLA-KIT X44A Standard (Cartouche, Screen, Sieb 1,6)	*CKX44-STD-02

POS.	DESCRIPTION	DESCRIPTION	BESCHREIBUNG	MAT.	CLA-VAL Nr.
1	Corps X44A-1	Body X44A-1	Gehäuse X44A-1	BRZ	57094
1.1	Corps X44A-3	Body X44A-3	Gehäuse X44A-3	BRZ	57095
2	Bouchon supérieur	Plug	Zapfen	303	57333
3	Joint torique	O-ring	O-Ring	RBR	00713J (a/b)
4	Cartouche 0,2	Screen 0,2	Sieb 0,2	MO4	68373A (a)
4.1	Cartouche 1,6	Screen 1,6	Sieb 1,6	316	57332 (b)
5	Buse 0,8	Orifice plug 0,8	Düse 0,8	DEL	57227
5.1	Buse 1,0	Orifice plug 1,0	Düse 1,0	DEL	57227-01
5.2	Buse 1,2	Orifice plug 1,2	Düse 1,2	DEL	57227-02
5.3	Buse 1,6	Orifice plug 1,6	Düse 1,6	DEL	57227-03
5.4	Buse 2,0	Orifice plug 2,0	Düse 2,0	DEL	57227-04
5.5	Buse 2,4	Orifice plug 2,4	Düse 2,4	DEL	57227-05
5.6	Buse 2,8	Orifice plug 2,8	Düse 2,8	DEL	57227-06
5.7	Buse 3,2	Orifice plug 3,2	Düse 3,2	DEL	57227-07
5.8	Buse 3,6	Orifice plug 3,6	Düse 3,6	DEL	57227-08
5.9	Buse 4,0	Orifice plug 4,0	Düse 4,0	DEL	57227-09
5.10	Buse 4,8	Orifice plug 4,8	Düse 4,8	DEL	57227-10
6	Joint torique	O-ring	O-Ring	RBR	00751J (a/b)
7	Bouchon filtre	Strainer plug	Filter Zapfen	303	57334
-	Bouchon X44A-3	Plug X44A-3	Zapfen X44A-3	316	BGT0001

Robinet de barrage à bille

Corps laiton nickelé ou inox, mécanisme interne en inox

Isolation Ball Valve

Stainless steel or nickel plated body, stainless steel 303 trim

Kugelhahn

Gehäuse aus vernickeltem Messing oder Edelstahl, Innenteile aus Edelstahl

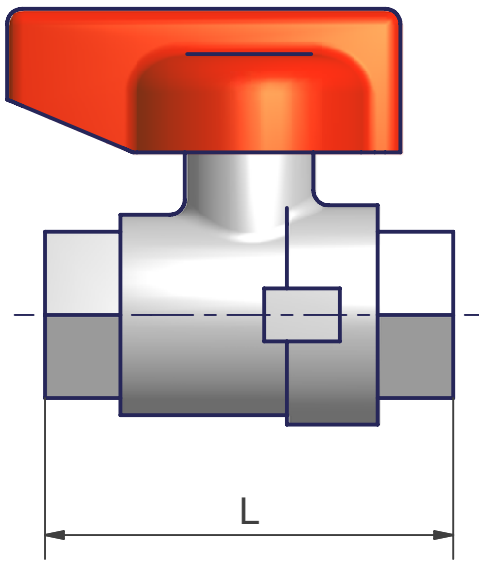

Rp	3/8"	1/2"	3/4"	1"
L	49	61	70	84
A	85	85	105	105

Type : M

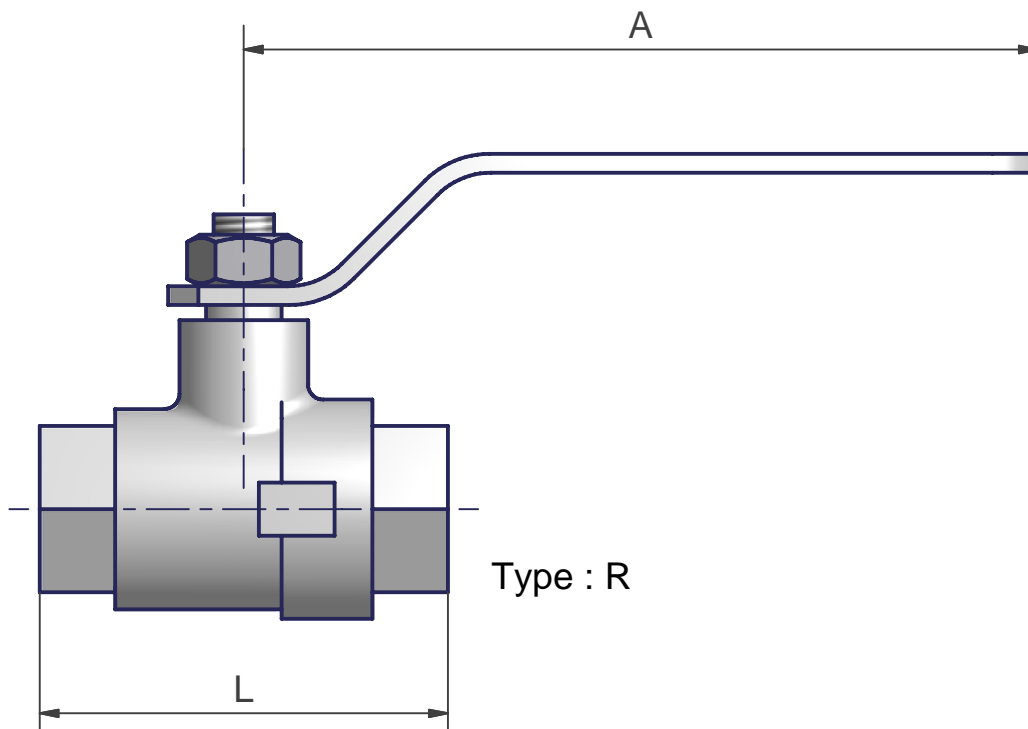

Type : R



CLA-VAL Form

Valve Specification





Client / Contact:	
Ref.:	Date:





HYDRAULIC PARAMETERS			
A	Maximum flow rate (Q peak consumption)		l/s
	Upstream dynamic pressure (at Q peak)		bar
	Minimum flow rate (Q night)		l/s
	Upstream static pressure (at Q night)		bar
	Intermittent max. flow rate (Q fire)		l/s
B	Back-pressure (water level in reservoir)		m

SETTING			
C	Flow rate		l/s
D	Surge flow rate (surge flow closing)		l/s
E	Downstream pressure		bar
F	Surge pressure rate (surge pressure closing)		bar
G	Upstream pressure or relief pressure		bar
I	$\Delta P > 20$ bar <input type="checkbox"/> Yes => <input type="checkbox"/> No		bar

J	SCHEMATIC

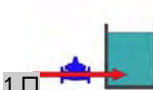
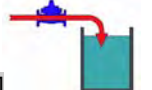
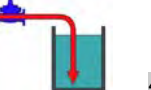
CLA-VAL MAIN VALVE																	
K		<input type="checkbox"/> NGE		<input type="checkbox"/> NGE-316		<input type="checkbox"/> GE		<input type="checkbox"/> AE		<input type="checkbox"/> TYTAN		<input type="checkbox"/> TDV					
																	
DN	Rp	DN	Rp	DN	Rp	DN	Rp	DN	Rp	DN	Rp	DN	Rp	DN	Rp	DN	Rp
32	1 1/4"					<input type="checkbox"/>	<input type="checkbox"/>	<input type="checkbox"/>	<input type="checkbox"/>								
40	1 1/2"			<input type="checkbox"/>		<input type="checkbox"/>	<input type="checkbox"/>	<input type="checkbox"/>	<input type="checkbox"/>								
50	2"	<input type="checkbox"/>		<input type="checkbox"/>		<input type="checkbox"/>	<input type="checkbox"/>	<input type="checkbox"/>	<input type="checkbox"/>								
65	2 1/2"	<input type="checkbox"/>		<input type="checkbox"/>		<input type="checkbox"/>	<input type="checkbox"/>	<input type="checkbox"/>	<input type="checkbox"/>								
80	3"	<input type="checkbox"/>		<input type="checkbox"/>		<input type="checkbox"/>	<input type="checkbox"/>	<input type="checkbox"/>	<input type="checkbox"/>			<input type="checkbox"/>					
100		<input type="checkbox"/>		<input type="checkbox"/>		<input type="checkbox"/>		<input type="checkbox"/>				<input type="checkbox"/>					
125		<input type="checkbox"/>		<input type="checkbox"/>								<input type="checkbox"/>					
150		<input type="checkbox"/>		<input type="checkbox"/>		<input type="checkbox"/>		<input type="checkbox"/>				<input type="checkbox"/>					
200		<input type="checkbox"/>		<input type="checkbox"/>		<input type="checkbox"/>		<input type="checkbox"/>				<input type="checkbox"/>					
250		<input type="checkbox"/>				<input type="checkbox"/>		<input type="checkbox"/>				<input type="checkbox"/>					
300		<input type="checkbox"/>				<input type="checkbox"/>		<input type="checkbox"/>									
350		<input type="checkbox"/>				<input type="checkbox"/>		<input type="checkbox"/>									
400		<input type="checkbox"/>				<input type="checkbox"/>		<input type="checkbox"/>									
450		<input type="checkbox"/>															
500		<input type="checkbox"/>															
600		<input type="checkbox"/>															
S 600												<input type="checkbox"/>					
S 700												<input type="checkbox"/>					
S 800												<input type="checkbox"/>					
M 900												<input type="checkbox"/>					
M 1000												<input type="checkbox"/>					
L 900												<input type="checkbox"/>					
L 1000												<input type="checkbox"/>					
L 1200												<input type="checkbox"/>					

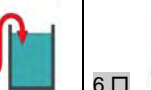
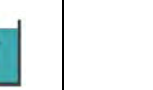
VALVE INSTALLATION					
L	<input type="checkbox"/> 	<input type="checkbox"/> 	<input type="checkbox"/> 	<input type="checkbox"/> 	<input type="checkbox"/> 

LEVEL CONTROL INSTALLATION						
M	<input type="checkbox"/> 	<input type="checkbox"/> 	<input type="checkbox"/> 	<input type="checkbox"/> 	<input type="checkbox"/> 	<input type="checkbox"/> 
	Reservoir <input type="checkbox"/> Open		Reservoir <input type="checkbox"/> Closed		<input type="checkbox"/> Constant level	<input type="checkbox"/> 2 levels (high and low)
					<input type="checkbox"/> 1 high level	<input type="checkbox"/> 1 low level

ELECTRICAL SPECIFICATIONS								
N	When switched off, the main valve is:		(Type D) <input type="checkbox"/> Opened		(Type E) <input type="checkbox"/> Closed		Notes:	
		Standard						
	Voltage	<input type="checkbox"/> 220 V	<input type="checkbox"/> 110 V	<input type="checkbox"/> 48 V	<input type="checkbox"/> 36 V	<input type="checkbox"/> 24 V	<input type="checkbox"/> 24 V	<input type="checkbox"/> Other:
	Frequency	<input type="checkbox"/> 50 Hz	<input type="checkbox"/> VDC	<input type="checkbox"/> Other:				
Mode	<input type="checkbox"/> Mono-stable		<input type="checkbox"/> Bi-stable					



STANDARD CLA-VAL VALVES: Catalog and Website

Downstream Control			Upstream Control			Flow Rate Control			Level Control		
<input type="checkbox"/> 90-01	AEL	OIO	<input type="checkbox"/> 50-01	AGL	OI-	<input type="checkbox"/> 40-01	ACL	OI-	<input type="checkbox"/> 100-CF9	ABLM	OI-
<input type="checkbox"/> 90-CF9	ABELM	OIO	<input type="checkbox"/> 50-CF9	ABGLM	OI-	<input type="checkbox"/> 40-CF9	ABCLM	OI-	<input type="checkbox"/> 113-CF9	ABLM	OI-
<input type="checkbox"/> 91-01	AEL	OIO	<input type="checkbox"/> 51-01	AGL	OI-	<input type="checkbox"/> 41-01	ACL	OI-	<input type="checkbox"/> 427-01	ABLM	OI-
<input type="checkbox"/> 93E/D-01	AELN	OIO	<input type="checkbox"/> 58E/D-01	AGLN	OI-	<input type="checkbox"/> 43E/D-01	ACLN	OI-	<input type="checkbox"/> 429-01	ABLMN	OI-
<input type="checkbox"/> 92-01	AEGL	OIO	<input type="checkbox"/> 52-03	AEGL	OI-	<input type="checkbox"/> 45-01	ACGL	OI-	<input type="checkbox"/> 208-01	ABLM	OI-
<input type="checkbox"/> 92-02	AEGL	OIO	<input type="checkbox"/> 52-03R	AEGL	OI-	<input type="checkbox"/> 49-01	ACEL	OIO	<input type="checkbox"/> 210-01	ABLM	OI-
<input type="checkbox"/> 94-01	AEFL	OIO							<input type="checkbox"/> 210-16	ABLM	OI-
<input type="checkbox"/> 94-16	AEFGL	OIO							<input type="checkbox"/> 210-21	ABCLM	OI-
									<input type="checkbox"/> 210-31	ABLM	OI-
									<input type="checkbox"/> 210-66	ABGLM	OI-

↑
Hydraulic parameters
And required settings

Standard Equipment:

Upstream manometer →	O
Position indicator X101 →	I
Downstream manometer →	O

Pump Control			Network Protection			Electrical Control		
<input type="checkbox"/> 60-31/02	AEGL	OI-	<input type="checkbox"/> 81-01	AL	OI-	<input type="checkbox"/> 136E/D-01	ALN	OI-
<input type="checkbox"/> 60-31/72	AEGL	OI-	<input type="checkbox"/> 81-02	AL	OI-	<input type="checkbox"/> 136E/D-03	ALN	OI-
<input type="checkbox"/> 60-81	AEGL	OI-	<input type="checkbox"/> 85-01	ADL	OI-	<input type="checkbox"/> 136-07	ALN	OI-
			<input type="checkbox"/> 85-03	ADL	OI-	<input type="checkbox"/> 136-38	ALN	OI-
			<input type="checkbox"/> 85-18	AFL	OI-			

ECO			PLC			PCM			MVE		
<input type="checkbox"/> 32-07	ALN	OI-	<input type="checkbox"/> 137/38/39-001	AEGLN	OI-	<input type="checkbox"/> 100-01	ABLM	OI-	<input type="checkbox"/> 137/38/39-500	ACLN	OI-
<input type="checkbox"/> 100-31	ABLMN	OI-	<input type="checkbox"/> 137/38/39-400	ACLN	OI-	<input type="checkbox"/> 90-01	AEL	OIO			
<input type="checkbox"/> 136-01	ALN	OI-	<input type="checkbox"/> 137/38/39-402	ACLN	OI-	<input type="checkbox"/> 50-01	AGL	OI-			
<input type="checkbox"/> 417-07	ABLMN	OI-	<input type="checkbox"/> 137/38/39-201	ABLMN	OI-	<input type="checkbox"/> 40-01	ACL	OI-			
			<input type="checkbox"/> 137/38/39-100	ABLMN	OIO		OI-				

P		OPTIONAL FEATURES			
<input type="checkbox"/> A	Flow Clean Strainer (X46A)	<input type="checkbox"/> O	Nylon Pipe Dia. 6/3 mm (STD with SERIE 40)	<input type="checkbox"/> W2	Opening Limiter (Level Control)
<input type="checkbox"/> C	One-Way Flow Control (Closing Speed) (CV)	<input type="checkbox"/> P	2-Way Pressure Cock (STD with SERIE 40)	<input type="checkbox"/> Y	High Capacity Strainer (X43/80-EP)
<input type="checkbox"/> F	Remote Pressure Sensing	<input type="checkbox"/> P1	Isolation Ball Valve	<input type="checkbox"/> Y2	Double Strainer (2 x X43)
<input type="checkbox"/> H	Solenoid Drain to Atmosphere	<input type="checkbox"/> S	One-Way Flow Control (Opening Speed) (CV)	<input type="checkbox"/> Y3	Double Strainer (1 x X43/80-EP + 1 x X43)
<input type="checkbox"/> H1	Solenoid Drain to Main Valve Outlet	<input type="checkbox"/> T	Delayed Opening (Serie 210, 2 Levels)	<input type="checkbox"/> Y4	Double High Capacity Filter (2 x X43/80-EP)
<input type="checkbox"/> M	Manual Command (Drain to Main Valve Outlet)	<input type="checkbox"/> V	Independant Opening / Closing Speed Setting (VRE)		
<input type="checkbox"/> M1	Manual Command (Drain to Atmosphere)	<input type="checkbox"/> W1	Anti Freeze Feature (Level Control)		

Q		ACCESSORIES		Note, preset:	
Position Indicator X101		<input type="checkbox"/> No			
Mechanical Lift Limiter X102-A		<input type="checkbox"/> Yes			
Hydraulic Lift Limiter X102-F		<input type="checkbox"/> Yes			
Magnetic Switch Assembly X105-M (1 A max)		<input type="checkbox"/> Yes	<input type="checkbox"/> 1 contact (X105-MCW)	<input type="checkbox"/> 2 contacts (X105-M2W)	
Electronic Valve Position Indicator e-Lift		<input type="checkbox"/> Yes	<input type="checkbox"/> 2 alarms	<input type="checkbox"/> 4 alarms	
Upstream Manometer		<input type="checkbox"/> No	<input type="checkbox"/> 0-16 bar (STD)	<input type="checkbox"/> 0-10 bar	<input type="checkbox"/> Other:
Downstream Manometer		<input type="checkbox"/> No	<input type="checkbox"/> 0-16 bar (STD)	<input type="checkbox"/> 0-10 bar	<input type="checkbox"/> Other:
Upstream manometer connector		<input type="checkbox"/> No	<input type="checkbox"/> CSA-12 (STD)	<input type="checkbox"/> CSA-11	<input type="checkbox"/> Other:
Downstream manometer connector		<input type="checkbox"/> No	<input type="checkbox"/> CSA-12 (STD)	<input type="checkbox"/> CSA-11	<input type="checkbox"/> Other:
Other:		<input type="checkbox"/>			

FLANGES DN ≤ 600			Standard Test CLA-VAL IT123		
R	Flange drilling (CLASS)		Pressure (bar)	Test pressure (bar)	
			PFA	PT1	PT2
<input type="checkbox"/>	ISO PN 10		10 bar	15 bar	11 bar
<input type="checkbox"/>	ISO PN 16		16 bar	25 bar	18 bar
<input type="checkbox"/>	ISO PN 25		25 bar	38 bar	28 bar
<input type="checkbox"/>	ISO PN 40		40 bar	44 bar	44 bar
<input type="checkbox"/>	ANSI 125		175 psi (12 bar)	18 bar	14 bar
<input type="checkbox"/>	ANSI 150		250 psi (17 bar)	26 bar	19 bar
<input type="checkbox"/>	ANSI 250		400 psi (28 bar)	42 bar	31 bar
<input type="checkbox"/>	ANSI 300		400 psi (28 bar)	42 bar	31 bar
On request:			<input type="checkbox"/> CE Test IT122	<input type="checkbox"/> Air Test IT125	<input type="checkbox"/> TYTAN Test IT126

Definitions:

PFA: Allowable operating pressure: Maximum hydrostatic pressure that a component is capable of withstanding continuously in service.

PT1: Test Pressure 1: Pressure test used for: ← Shell pressure test.

PT2: Test Pressure 2: Pressure test used for: ↑ Pilot system pressure test.

→ Seat tightness test.

↓ Diaphragm tightness test.

TYPE OF FLUID AND CLA-VAL STANDARDS				
S	<input type="checkbox"/> Drinking water	<input type="checkbox"/> Industrial water	<input type="checkbox"/> Brackish water	Temperature:
	<input type="checkbox"/> Irrigation water	<input type="checkbox"/> Demineralised water	<input type="checkbox"/> Sea water	<input type="checkbox"/> Material in suspension

CLA-VAL STANDARDS FOR MATERIAL		Main valve	Pilot circuit
T	<ul style="list-style-type: none"> • Drinking water (PN 10-25) • Irrigation water • Active Cl < 0,30 mg/l • Total salts < 1,0 g/l <input type="checkbox"/> STD (Standard)	NGE / GE / AE / EAE / TDV <ul style="list-style-type: none"> • Body: ductile iron* • Mechanism**: SS 303 • Bolting: SS 303 	<ul style="list-style-type: none"> • Body: bronze • Mechanism: SS 303
	<ul style="list-style-type: none"> • Drinking water (PN 40+) • Industrial water • Active Cl < 0,50 mg/l • Total salts. < 5,0 g/l <input type="checkbox"/> WWS (Waterworks)	NGE-316 / Roll Seal <ul style="list-style-type: none"> • Body: SS 316 • Mechanism**: SS 303 • Bolting: SS 303 	<ul style="list-style-type: none"> • Body: SS 316L • Mechanism: SS 303 minimum
	<ul style="list-style-type: none"> • Industrial water • Brackish water • Active Cl < 1,00 mg/l • Total salts < 10,0 g/l <input type="checkbox"/> IND (Industry)	NGE-316 / Roll Seal <ul style="list-style-type: none"> • Body: SS 316 • Mechanism**: SS 316 • Bolting: SS 316 	<ul style="list-style-type: none"> • Body: SS 316L • Mechanism: SS 316 minimum
	<ul style="list-style-type: none"> • Brackish water • Sea water • Active Cl < 1,00 mg/l • Total salts < 40,0 g/l <input type="checkbox"/> OFS (Offshore, Marine)	NGE-316 / Roll Seal <ul style="list-style-type: none"> • Body: SS 316 • Mechanism**: Monel • Bolting: SS 316 	<ul style="list-style-type: none"> • Body: SS 316L • Mechanism: Monel minimum
	<ul style="list-style-type: none"> • Brackish water • Sea water • Active Cl < 0,30 mg/l • Total salts < 40,0 g/l <input type="checkbox"/> SWS (Sea Water Service)	NGE / GE / AE / EAE / TDV <ul style="list-style-type: none"> • Body: ductile iron* • Mechanism**: Monel • Bolting: SS 316 	<ul style="list-style-type: none"> • Body: marine grade bronze • Mechanism: Monel minimum
* Ductile iron: GGG 40 epoxy coated 250 µm min		** Mechanism: stem, stem nut and cover bearing. Standard seat and disc guide: SS 316	

CLA-VAL STANDARDS FOR ELASTOMERS		Active Cl	Total salts	Note
U	<input type="checkbox"/> EPDM	< 0,3 mg/l	< 10g/l	Standard CLA-VAL
	<input type="checkbox"/> NBR	< 0,3 mg/l	< 40g/l	
	<input type="checkbox"/> Viton or Teflon protection	> 0,3 mg/l	< 40g/l	
	<input type="checkbox"/> EPDM, Viton or Teflon protection	Ozone (O ₃)		

CLA-VAL STANDARDS FOR CALCAREOUS PROTECTION			
V	<input type="checkbox"/>	Neutral water (pH 7 - 9 / hardness: 15°F / active Cl < 0,1 mg/l)	STANDARD
	<input type="checkbox"/>	Aggressive water (CO ₂ attack, pH 6 - 7)	WWS minimum recommended
	<input type="checkbox"/>	Incrusting water (calcareous precipitation, hardness > 20°F)	Delrin (ΔP < 5 bar) or Teflon protection