

Pedestrian Guardrail

fixed & removable installation options

041-9832591 | info@ipl.ie | www.iplgroup.com

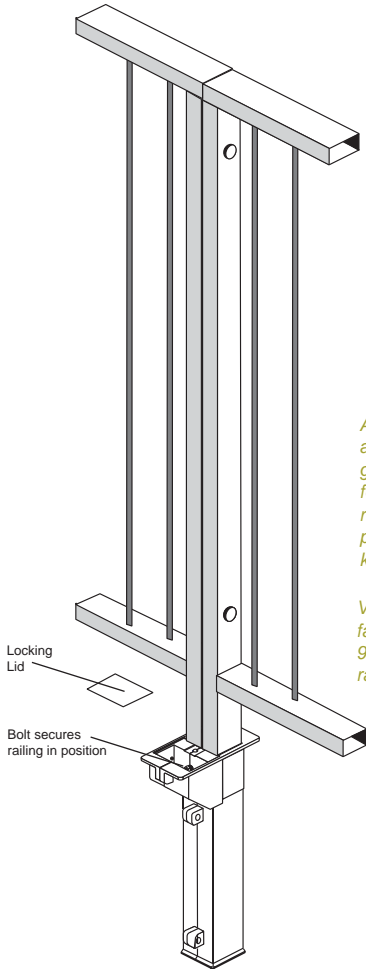

A combination of fixed and removable pedestrian guardrails may be used for easy maintenance and replacement of damaged panels in high-risk knockdown areas.

Versatile RS sockets facilitates end panels, 90° corners and radius bends.



Multi-purpose galvanised pedestrian guardrail for all pavements, roundabouts and traffic junctions.

features...

Strong galvanised steel box section railing with RS50x60 socket for easy installation and replacement.

options...

RS socket (for removable & locking option)
Panels with staggered vertical 12mm bars
Panel sizes: 2M / 1.5M / 1M

Maximum radius bends:
2M panel - 16 meters
1.5M panel - 12 meters
1M panel - 8 meters

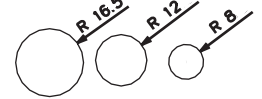

RETENTION SYSTEM™

THE INTELLIGENT FOUNDATION FOR POST INSTALLATION

Versatility & foresight:
Specifying the use of RS sockets anticipates the expected installation demands, maintenance needs and lifecycle of the post.

www.retention-system.com

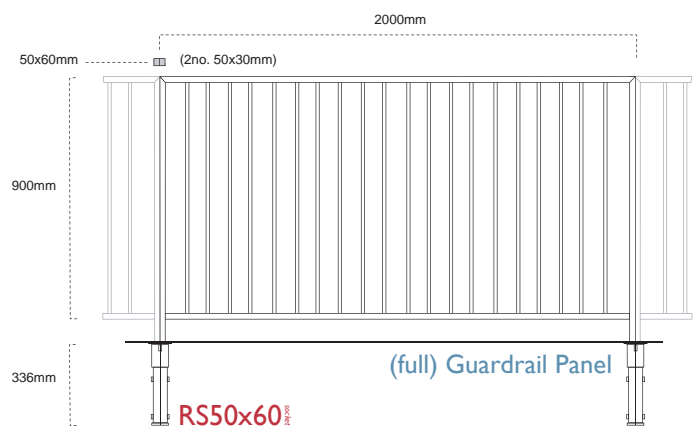
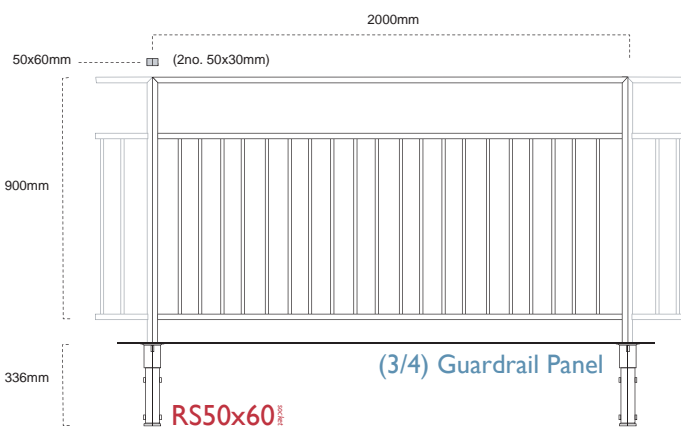

design | identity | security

Galvanised PGrail (code)	¾ GPGR (2M)	full GPGR (2M)	(Panel lengths 2M / 1.5M / 1M available)	MADE IN IRELAND
Height (above ground):	1000mm	1000mm		
Depth (below ground):	340mm	340mm		
Box Section (core post):	50x30mm	50x30mm		
Total Weight:	40kg	37kg		
RS socket option:	RS50x60	RS50x60		

Further advice on the RETENTION SYSTEM and Rivers street furniture including specific installation requirements is available from IPL group. Measurements and weights are approximate. The designs are the property of Innovative Products Ltd (IPL group) and may not be reproduced without express permission. Innovative Products reserve the right to amend specifications or to withdraw models without prior notice. © May 2008.

