

Specification

- ◆ Ductile Iron (Spheroidal Graphite)
- ◆ BS2789 / EN-GJS-500-7 (Material Standard)
- ◆ EN124 - Class B125/D400 (Product Standard)
- ◆ LRQA (Lloyds Certification)

Features

- ◆ Octagonal Design For Easy Installation
- ◆ Flush Kerbside Finish
- ◆ Multi-Directional Access Slots
- ◆ Spare Access Slots Sealed With Blanking Plates
- ◆ Base Spigot Secures 100mm & 50mm Duct*
- ◆ Side Access Option*
- ◆ Single Cover
- ◆ Non-Rock Action
- ◆ Open Keyhole
- ◆ Black Bitumen Coated
- ◆ Customised Badging Option

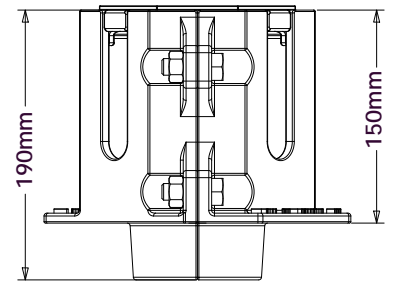
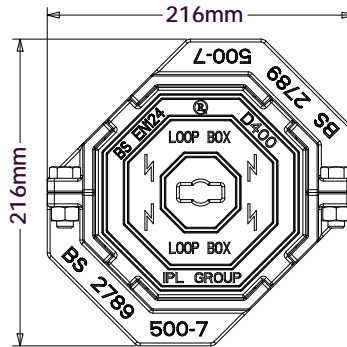

Carriageway Loop Box
for roadside access
to underground cables

[eg. traffic counting / automatic vehicle recognition / car park access]



*duct not included



Product Code
C-AD400



IPL group

Slane Road, Drogheda,
Co. Louth, Ireland.
Tel: +353 41 983 2591
Fax: +353 41 983 2599
Email: info@ipl.ie
Website: www.iplgroup.com

Technical Data

EN124 Class	Frame Opening (mm)	Frame Size (mm)	Frame Depth (mm)	Weight (kg)	Waterway Area
B125/D400	n/a	216x216	190(150+40)	10.5	n/a

Group 4: Carriageways of roads (including pedestrian streets), hard shoulders and parking areas for all types of road vehicles.



Further information on ORBITAL access covers and gratings is available at www.iplgroup.com
Measurements and weights are approximate. The designs are the property of Innovative Products Ltd (IPL group) and may not be reproduced without express permission. Innovative Products reserve the right to amend specifications or to withdraw models without prior notice. © June 2011.