

Xlast[®]

by sabacauchó

FLEXIBLE & SAFETY BOLLARDS

IPL group distributor catalogue



IPL group recommend the installation of Xlast bollards in RETENTION SYSTEM™ sockets.



ipl group

www.iplgroup.com

IPL group, Slane Road, Drogheda, Co. Louth, Ireland. Tel: +353 41 9832591 | Fax: +353 41 9832599 | Email: info@ipl.ie | Website: www.iplgroup.com



Stiffness tests



Resistance testing



Apparent strength tests

X-last[®], the safest and most durable bollard

After several years of research, Sabacauchó presents a new concept in bollards: the X-last[®] bollard.

Made of a new material, with exclusive properties, the **X-last[®] bollards have maximum resistance and flexibility**, which convert them into the safest and most durable bollards.

Thanks to their stiffness, they fully comply with the function of preventing vehicles from entering prohibited zones; but it is their flexibility which make them virtually impossible to be broken, and after being knocked down, **they return to their original position and form.**

These bollards cannot be broken or dented and are not affected by rust... and we can make them in attractive customised designs in record time, as shown with our LookArT[®] proposals.

X-last[®] bollards are guaranteed to last practically a lifetime and do not need to be replaced. That flexibility makes them **extra safe compared to other metal bollards** that are anchored to the ground and can cause serious harm to vehicles and people.

X-last[®], the safest, most durable, flexible and resistant bollard.

Our objective is to help you to redesign your streets with X-last[®] and make them safer, more practical and more modern and attractive.



X-last,[®] accessibility

Our products are in accordance with the requirements for the accessibility of the public road network (garbage dump) and the public places. We conceive the bollards geometry which (Heights and Diameters) is in compliance with the current abacuses and there design integrates reagent covers allowing the contrast of the product in its environment in order to increase their visibility. Information in conventional writing and/or Braille can be integrated during the molding on the said tactile parts of the bollards to facilitate the accessibility to all in our environment.

Access to the emergency vehicles

The shape memory bollard X-last[®] minimizes the damages caused in the human body during impacts while performing perfectly the function to prevent a vehicle of tourism from parking on a restricted zone. Due to their flexibility and resistance, they also allow the fire trucks to pass above without being obliged to remove them before or to change them after intervention.

The X-last[®] bollard is the safest, the most sustainable, the most flexible and most resistant bollard of the market.

SOS
TENIBI
LITY



X-last[®], the ecologic option

The X-last[®] bollard has 50% less impact on environment than the traditional metallic bollards.

For several years Sabacauchó, integrate as additional technical criterion **the sustainable development** and this from the phase of development of every product.

In our trial of development of product, besides the functional, aesthetic criteria, legal and specific characteristics imposed by every customer, we analyze the concept, the materials, the manufacturing process, and the evolution of the characteristics during its useful life expectancy. Also we investigate the alternatives of elimination of this product **while looking for the best compromise between cost, services(performances) and protection on the environment.**

The fruit of this work, brought to us to the realization of the X-last[®] Bollard which generates 50 % less impact on the environment than the conventional metallic bollards, according to the study of the **ACV (Analysis of the Life Cycle)** realized by the European foundation **INASMET-Tecnalia.**

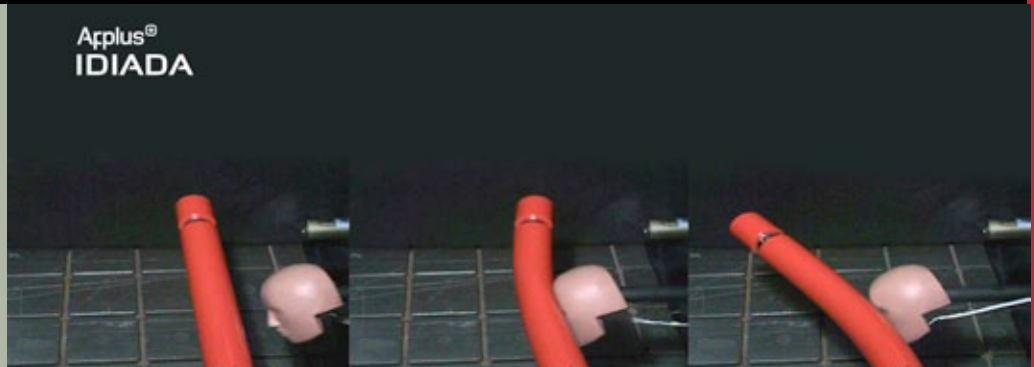

X-last[®], safety

X-Last[®] bollards save lives.

The Applied research automotive center (**IDIADA Automotive Technology**) has realized impacts test with X-last [®] bollards and metallic ones.

At a speed of 40 Km/h, which is a most common speed limit in cities centers, metallic bollards cause irreversible injuries on persons.

There is an international criterion which is used to evaluate injuries caused on the head of a person after impacts. This criterion is called **HIC** (Head Injury Criterion).

The maximum value beyond which there are irreversible injuries is **1000**.

At 40 km/h, the test made in IDIADA research center have proved that the HIC criterion obtained after the impact of a human head on a metallic bollard is 4600.

This is almost 5 times the international limit.

At the same impact speed, the results with the X-Last[®] bollard are spectacular, because the HIC criterion obtained after the impact of a human head is 460.

This is less than half of the international limit and **10 times less than the results on the metallic bollards.**

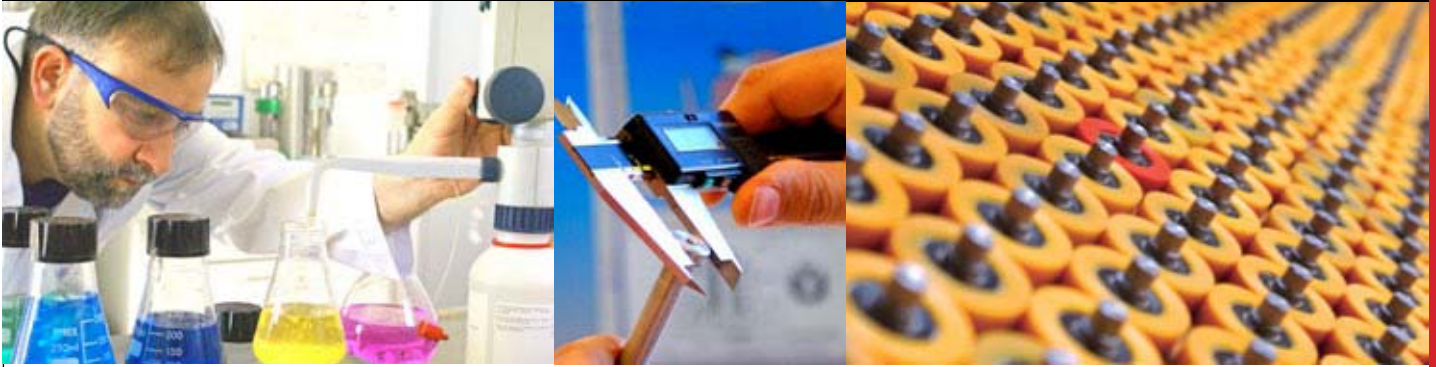

X-last[®] technology

In SABACAUCHO we invest in Research Development & Innovation, developing innovative solutions.

Founded in 1979, we solve problems related with flexibility, strength, sliding, abrasion, grip, elasticity, etc.

We create and provide solutions with the very highest resistance against tear, compression, breakage, abrasion, impact, humidity, water, dissolvent's, ageing, high temperatures, hydrocarbons, etc., in accordance with orders and/or specifications.

We make your problem our problem, and we solve it. Result of this philosophy, SABACAUCHO has designed an exclusive formula, X-last[®], a polymer composite including reinforcing nanoparticles, spectacular.

The X-last[®] formula obtains rigidity as high as that of a rigid material but with enough flexibility to be able to tolerate the impact of a car without breaking.

The quality and environmental management system of SABACAUCHO S.A.U, is certified in accordance with the ISO 9001:2008 and ISO 14001:2004 standards.

If a solution is possible, SABACAUCHO will find it. With agility. Guaranteed results.

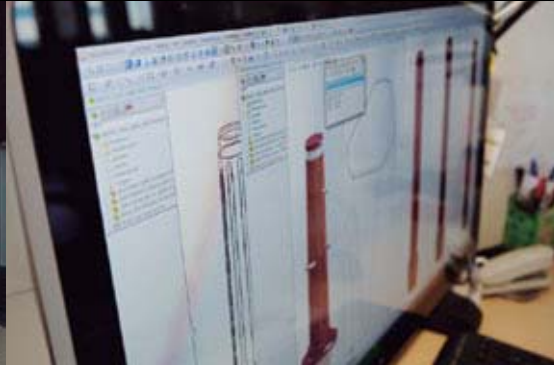

X-last[®] designs

We offer you all models with different surface finishes. Being the producers, we can realize customized bollards, with specific designs, such as with the coat of arms of your city or company. Special finishes are available or, if you prefer, we can produce your own custom exclusive type.

Our objective is to help you to redesign our streets with X-last[®] and make them safer, more practical and more modern and attractive.

Colours: The whole RAL colour range.

Finishes: Please enquire (metallic, matt, glossy). Possibility of customizing them with the city's coat-of-arms. Option of applying reflective or metallic tape.

Types of Fastenings: With formwork base (removable), in formwork and attached directly to the ground or using screws with a metal or chemical plug.



photomontage

Babyk

Red premium finishing
example

Colors

The whole RAL color range.

Finishes

Please enquire (metallic, matt, glossy). Possibility of customizing them with the city's coat-of-arms. Option of applying reflective or metallic tape.

Types of Fastenings

With socket (removable), attached directly to the ground or using screws with a metal or chemical plug.

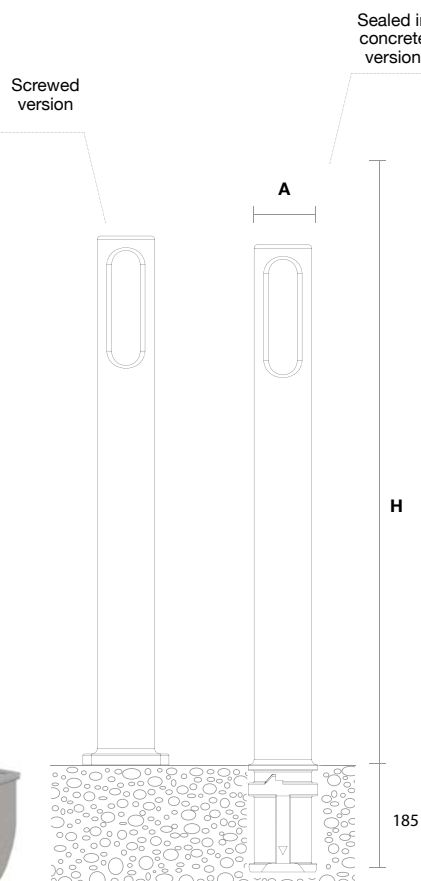

Dimensions in mm

A	H
100	900



RS115 www.retention-system.com

RETENTION SYSTEM™ sockets are intelligent foundation solutions for the installation and maintenance of posts.



real image

Baliza

Colors

The whole RAL color range.

Finishes

Please enquire (metallic, matt, glossy). Possibility of customizing them with the city's coat-of-arms. Option of applying reflective or metallic tape.

Types of Fastenings

With socket (removable), attached directly to the ground or using screws with a metal or chemical plug.



A	H
100	660
100	770
100	900
100	1050
100	1200

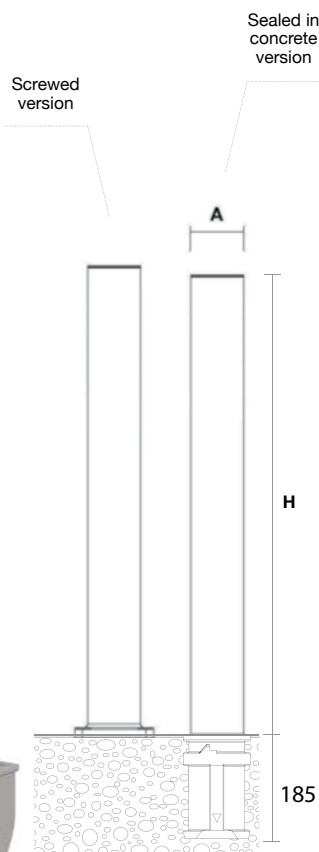

Red premium finishing
example (RAL 3020)



RS115 www.retention-system.com

RETENTION SYSTEM™ sockets are intelligent foundation solutions for the installation and maintenance of posts.



photomontage

Baliza D80

Colors

The whole RAL color range.

Finishes

Please enquire (metallic, matt, glossy). Possibility of customizing them with the city's coat-of-arms. Option of applying reflective or metallic tape.

Types of Fastenings

With socket (removable) or attached directly to the ground.



Dimensions in mm

A	H
80	800
80	900
80	1000
80	1100
80	1200



Gray excellence finishing
example (RAL 7035)



RS76 www.retention-system.com

RETENTION SYSTEM™ sockets are intelligent foundation solutions for the installation and maintenance of posts.



real image

Baliza Reflector

Red premium finishing
example (RAL 3020)

Colors

The whole RAL color range.

Finishes

Please enquire (metallic, matt, glossy). Possibility of customizing them with the city's coat-of-arms. Option of applying reflective or metallic tape.

Types of Fastenings

With socket (removable), attached directly to the ground or using screws with a metal or chemical plug.



Dimensions in mm

A	B	H
100	50	660
100	50	770
100	50	900
100	50	1050
100	50	1200

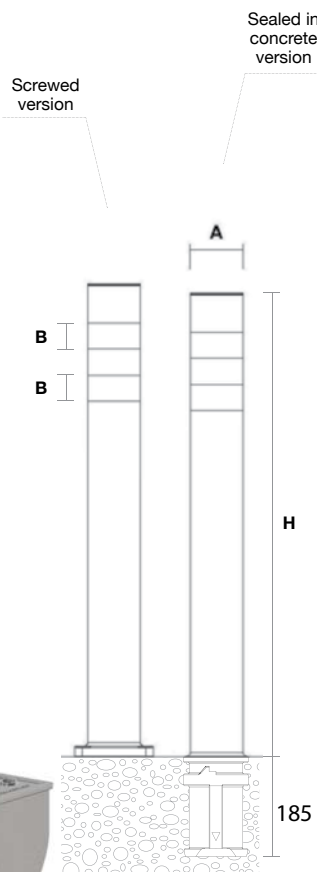

RS115 www.retention-system.com

RETENTION SYSTEM™ sockets are intelligent foundation solutions for the installation and maintenance of posts.



Baliza D150 Sign

Green premium finishing
example (RAL 6024)

Colors

The whole RAL color range.

Finishes

Please enquire (metallic, matt, glossy). Possibility of customizing them with the city's coat-of-arms. Option of applying reflective or metallic tape.

Types of Fastenings

With socket (removable), attached directly to the ground or using screws with a metal or chemical plug.



RETENTION SYSTEM™
sockets for post installation

Dimensions in mm

A	B	H
400	150	1330

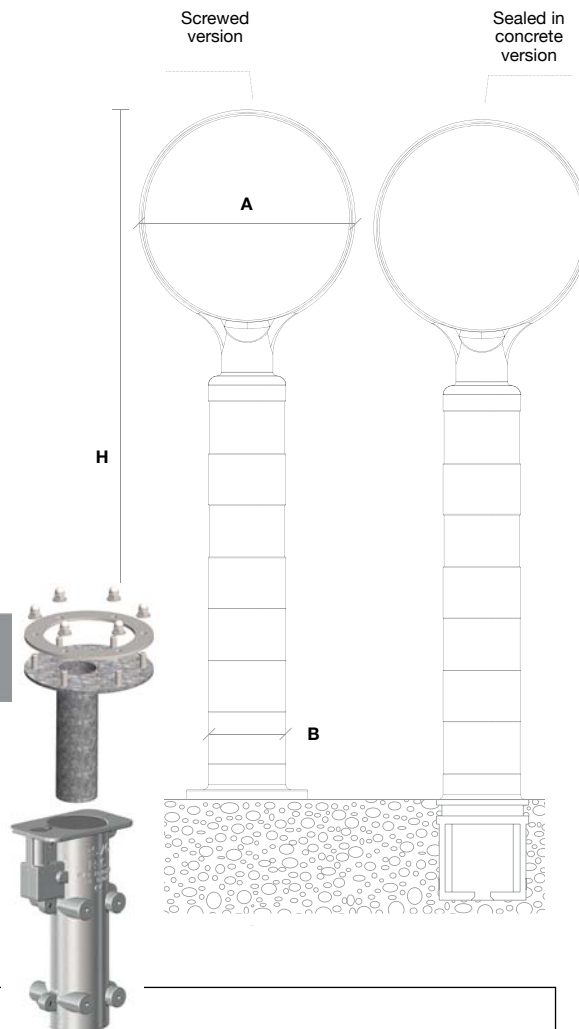

RSc76 www.retention-system.com

RETENTION SYSTEM™ sockets are intelligent foundation solutions for the installation and maintenance of posts.



Real Image

Boule

Colors

The whole RAL color range.

Finishes

Please enquire (metallic, matt, glossy). Possibility of customizing them with the city's coat-of-arms. Option of applying reflective or metallic tape.

Types of Fastenings

With socket (removable), attached directly to the ground or using screws with a metal or chemical plug.



Dimensions in mm

A	H
100	800
100	900
100	1050
100	1200

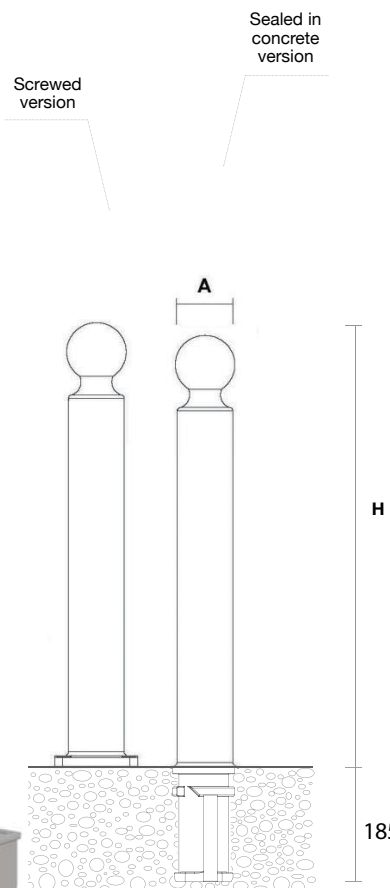

Metalized bicolor excellence
finishing example
(Black and palm color)



RS115 www.retention-system.com

RETENTION SYSTEM™ sockets are intelligent foundation solutions for the installation and maintenance of posts.



fotomontaje

Boule D80

Colors

The whole RAL color range.

Finishes

Please enquire (metallic, matt, glossy). Possibility of customizing them with the city's coat-of-arms. Option of applying reflective or metallic tape.

Types of Fastenings

With socket (removable) or attached directly to the ground.



Dimensions in mm

A	H
80	800
80	900
80	1050
80	1100
80	1200

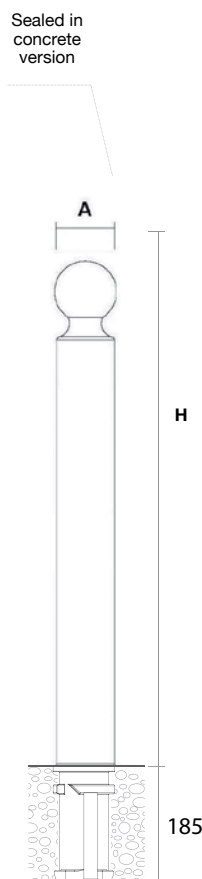

Bicolor excellence finishing
example (RAL 8019 + RAL 9016)



RS76 www.retention-system.com

RETENTION SYSTEM™ sockets are intelligent foundation solutions for the installation and maintenance of posts.



photomontage

Class

Colors

The whole RAL color range.

Finishes

Please enquire (metallic, matt, glossy). Possibility of customizing them with the city's coat-of-arms. Option of applying reflective or metallic tape.

Types of Fastenings

With socket (removable) or attached directly to the ground.



Dimensions in mm

A	B	C	H
100	115	150	900



Sealed in concrete version

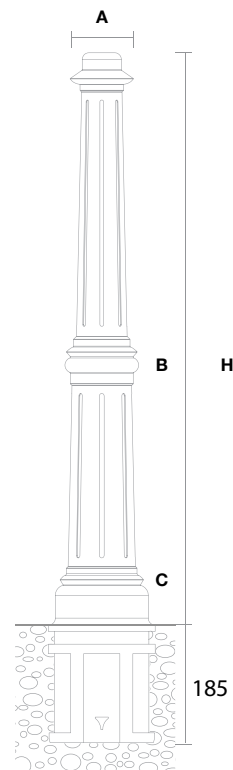

Green premium finishing example (RAL 6024)

RSc76 www.retention-system.com

RETENTION SYSTEM™ sockets are intelligent foundation solutions for the installation and maintenance of posts.



Gola

Colors

The whole RAL color range.

Finishes

Please enquire (metallic, matt, glossy). Possibility of customizing them with the city's coat-of-arms. Option of applying reflective or metallic tape.

Types of Fastenings

With socket (removable), attached directly to the ground or using screws with a metal or chemical plug.



Dimensions in mm

A	B	H
110	150	800

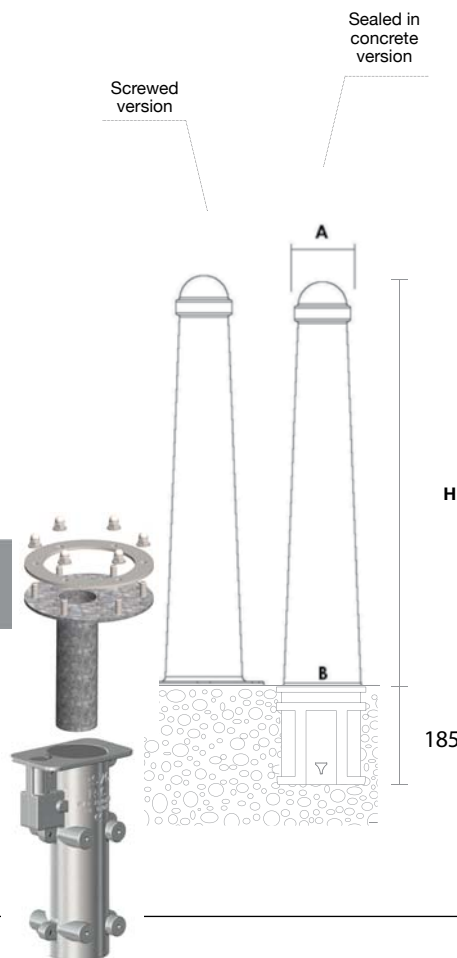

Yellow excellence finishing
example (RAL 1016)



RSc76 www.retention-system.com

RETENTION SYSTEM™ sockets are intelligent foundation solutions for the installation and maintenance of posts.



real image

Gola Reflector

Green premium finishing example (RAL 6024)

Colors

The whole RAL color range.

Finishes

Please enquire (metallic, matt, glossy). Possibility of customizing them with the city's coat-of-arms. Option of applying reflective or metallic tape.

Types of Fastenings

With socket (removable), attached directly to the ground or using screws with a metal or chemical plug.

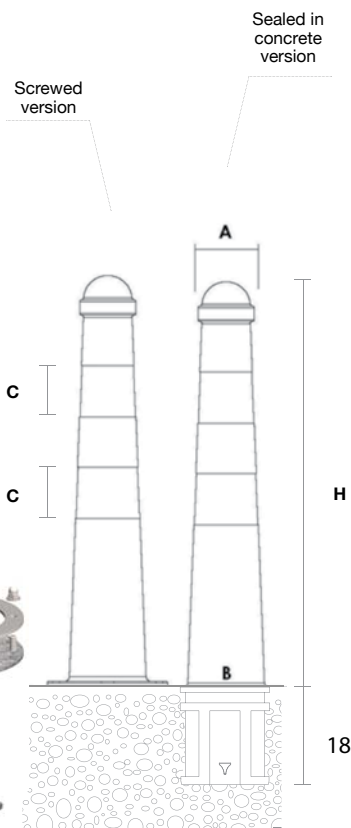

Dimensions in mm

A	B	C	H
110	150	100	800



RSc76 www.retention-system.com

RETENTION SYSTEM™ sockets are intelligent foundation solutions for the installation and maintenance of posts.



real image

Gorge

Colors

The whole RAL color range.

Finishes

Please enquire (metallic, matt, glossy). Possibility of customizing them with the city's coat-of-arms. Option of applying reflective or metallic tape.

Types of Fastenings

With socket (removable), attached directly to the ground or using screws with a metal or chemical plug.



Dimensions in mm

A	H
100	800
100	900
100	1050
100	1200

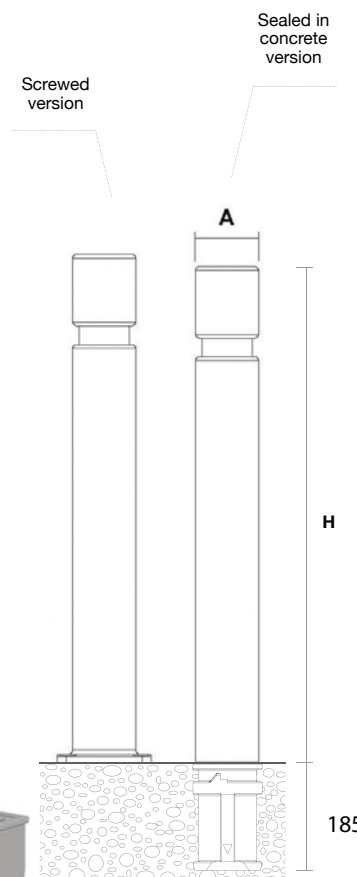

Black premium finishing
example



RS115 www.retention-system.com

RETENTION SYSTEM™ sockets are intelligent foundation solutions for the installation and maintenance of posts.



photomontage

Gorge D80

Black premium finishing
example

Colors

The whole RAL color range.

Finishes

Please enquire (metallic, matt, glossy). Possibility of customizing them with the city's coat-of-arms. Option of applying reflective or metallic tape.

Types of Fastenings

With socket (removable) or attached directly to the ground.



Dimensions in mm

A	H
80	800
80	900
80	1050
80	1100
80	1200

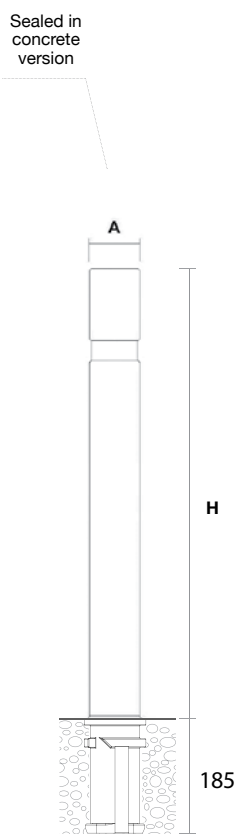

RS76 www.retention-system.com

RETENTION SYSTEM™ sockets are intelligent foundation solutions for the installation and maintenance of posts.



real image

Kreta

Black premium finishing
example

Colors

The whole RAL color range.

Finishes

Please enquire (metallic, matt, glossy). Possibility of customizing them with the city's coat-of-arms. Option of applying reflective or metallic tape.

Types of Fastenings

With socket (removable), attached directly to the ground or using screws with a metal or chemical plug.



Dimensions in mm

A	B	H
100	150	800

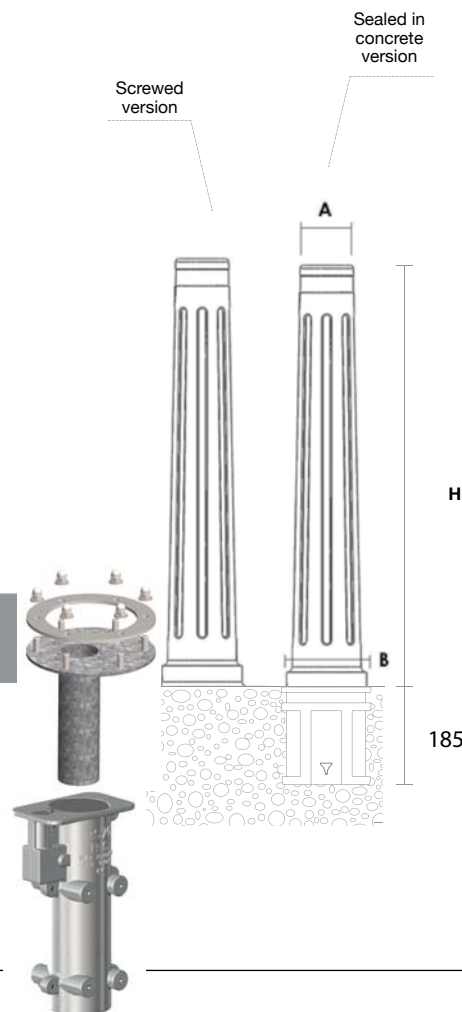

RSc76 www.retention-system.com

RETENTION SYSTEM™ sockets are intelligent foundation solutions for the installation and maintenance of posts.



photomontage

Krola

Colors

The whole RAL color range.

Finishes

Please enquire (metallic, matt, glossy). Possibility of customizing them with the city's coat-of-arms. Option of applying reflective or metallic tape.

Types of Fastenings

With socket (removable) or attached directly to the ground.



Dimensions in mm

A	B	H
110	150	970

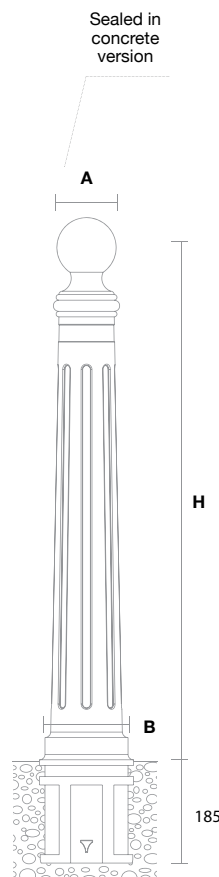

Metalized bicolor excellence
finishing example
(Black + copper metalized)



www.retention-system.com

RETENTION SYSTEM™ sockets are intelligent foundation solutions for the installation and maintenance of posts.



photomontage

Kuay

Colors

The whole RAL color range.

Finishes

Please enquire (metallic, matt, glossy). Possibility of customizing them with the city's coat-of-arms. Option of applying reflective or metallic tape.

Types of Fastenings

With socket (removable), attached directly to the ground or using screws with a metal or chemical plug.



Dimensions in mm

A	H
100	1000

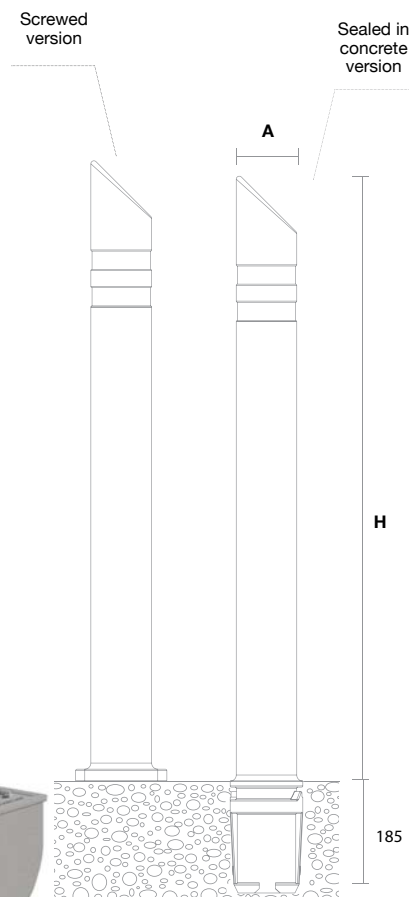

Gray metalized steel excellence
finishing example



RS115 www.retention-system.com

RETENTION SYSTEM™ sockets are intelligent foundation solutions for the installation and maintenance of posts.



photomontage

Lookart[®] Diamond

Colors

The whole RAL color range.

Finishes

Please enquire (metallic, matt, glossy). Possibility of customizing them with the city's coat-of-arms. Option of applying reflective or metallic tape.

Types of Fastenings

With socket (removable), attached directly to the ground or using screws with a metal or chemical plug.



Dimensions in mm

A	B	C	H
110	90	150	900

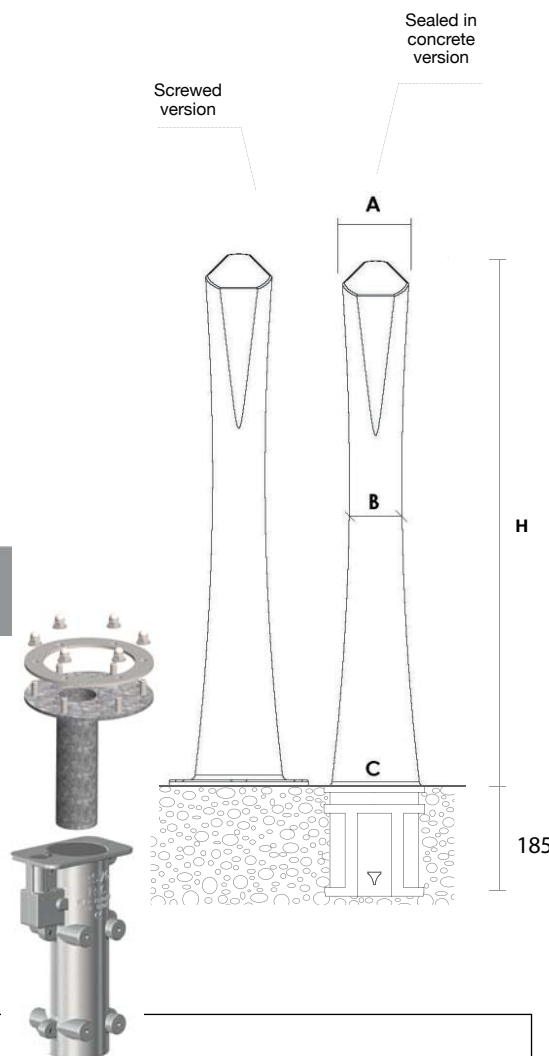

metallize gold excellence
finishing example

RSc76 www.retention-system.com

RETENTION SYSTEM™ sockets are intelligent foundation solutions for the installation and maintenance of posts.



photomontage

Nantes

Colors

The whole RAL color range.

Finishes

Please enquire (metallic, matt, glossy). Possibility of customizing them with the city's coat-of-arms. Option of applying reflective or metallic tape.

Types of Fastenings

With socket (removable) or attached directly to the ground.



Dimensions in mm

A	B	H
90	100	1000



Sealed in concrete version

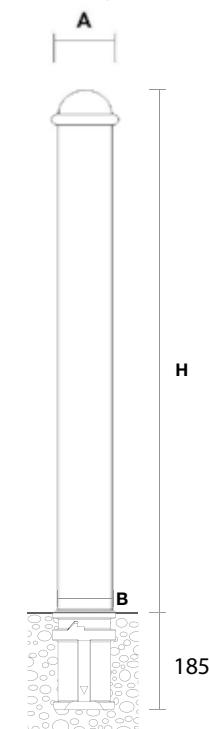

Maroon premium finishing
example (similar to RAL 3011)



RS115 www.retention-system.com

RETENTION SYSTEM™ sockets are intelligent foundation solutions for the installation and maintenance of posts.



photomontage

Nuvo

Black premium
finishing example

Colors

The whole RAL color range.

Finishes

Please enquire (metallic, matt, glossy). Possibility of customizing them with the city's coat-of-arms. Option of applying reflective or metallic tape.

Types of Fastenings

With socket (removable), attached directly to the ground or using screws with a metal or chemical plug.



Dimensions in mm

A	B	H
160	150	1000

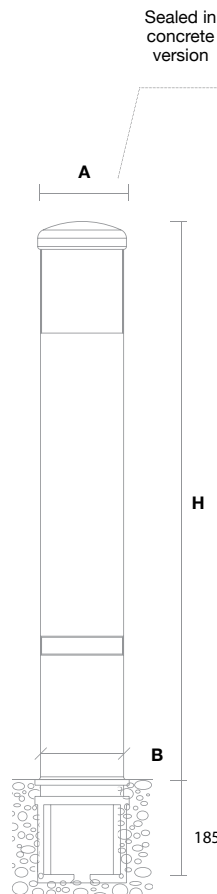

www.retention-system.com

RETENTION SYSTEM™ sockets are intelligent foundation solutions for the installation and maintenance of posts.



photomontage

Nuvo Reflector

Black premium
finishing example

Colors

The whole RAL color range.

Finishes

Please enquire (metallic, matt, glossy). Possibility of customizing them with the city's coat-of-arms. Option of applying reflective or metallic tape.

Types of Fastenings

With socket (removable), attached directly to the ground or using screws with a metal or chemical plug.



Dimensions in mm

A	B	H
160	150	1000

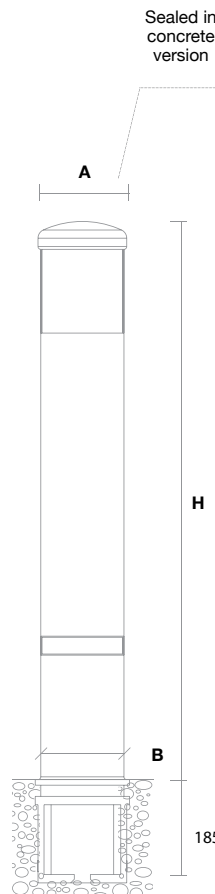

RSc76 www.retention-system.com

RETENTION SYSTEM™ sockets are intelligent foundation solutions for the installation and maintenance of posts.



photomontage

Nuvo Signal

Yellow premium
finishing example

Colors

The whole RAL color range.

Finishes

Please enquire (metallic, matt, glossy). Possibility of customizing them with the city's coat-of-arms. Option of applying reflective or metallic tape.

Types of Fastenings

With socket (removable), attached directly to the ground or using screws with a metal or chemical plug.



Dimensions in mm

A	B	H
170	150	1030

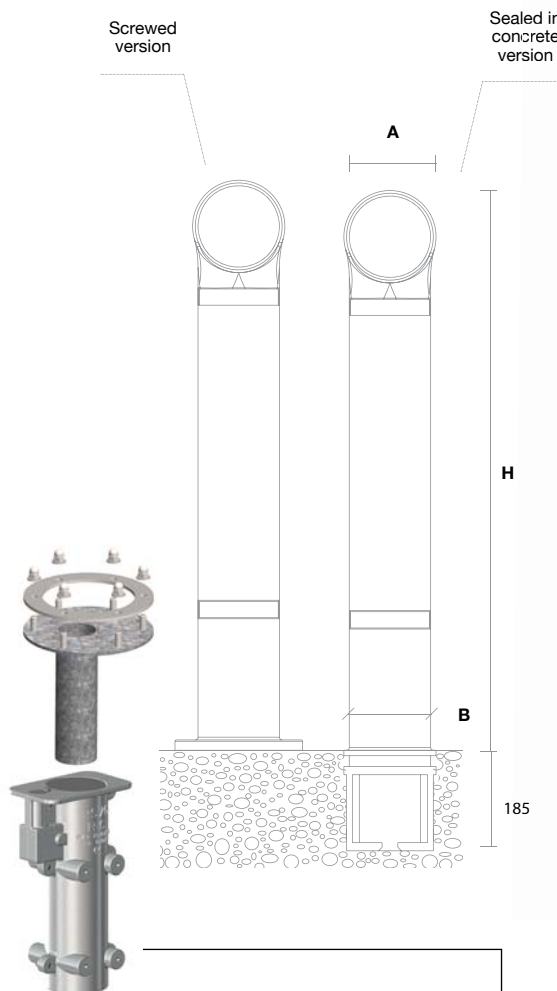

RSc76 www.retention-system.com

RETENTION SYSTEM™ sockets are intelligent foundation solutions for the installation and maintenance of posts.



photomontage

O-bus

Colors

The whole RAL color range.

Finishes

Please enquire (metallic, matt, glossy). Possibility of customizing them with the city's coat-of-arms. Option of applying reflective or metallic tape.

Types of Fastenings

With socket (removable), attached directly to the ground or using screws with a metal or chemical plug.



RETENTION SYSTEM™
sockets for post installation

Dimensions in mm

A	B	H
110	150	1400

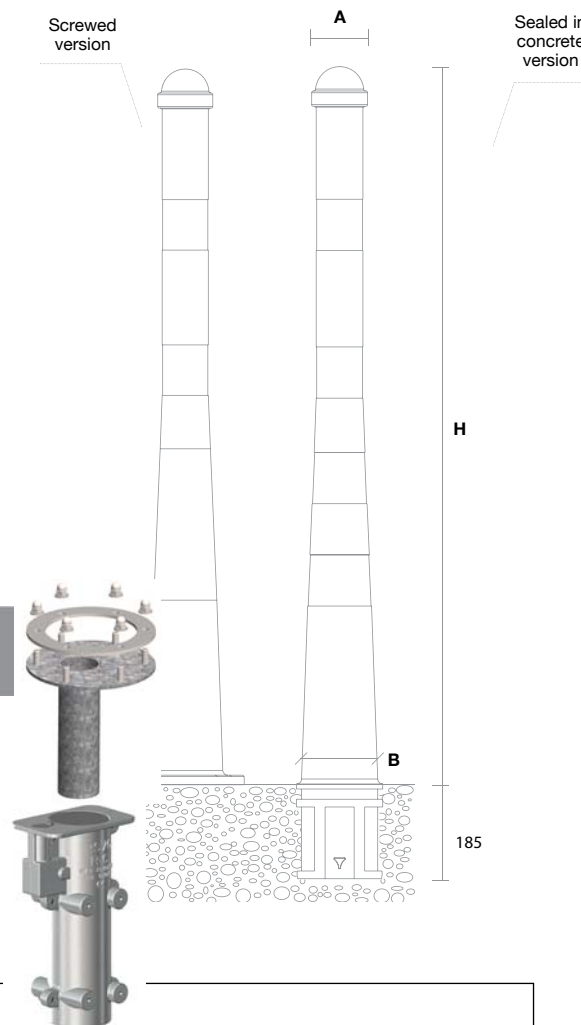

Translucent white excellence
finishing exemple



RSc76 www.retention-system.com

RETENTION SYSTEM™ sockets are intelligent foundation solutions for the installation and maintenance of posts.



photomontage

Wat

Colors

The whole RAL color range.

Finishes

Please enquire (metallic, matt, glossy). Possibility of customizing them with the city's coat-of-arms. Option of applying reflective or metallic tape.

Types of Fastenings

With socket (removable) or attached directly to the ground.



Dimensions in mm

A	B	H
90	100	980

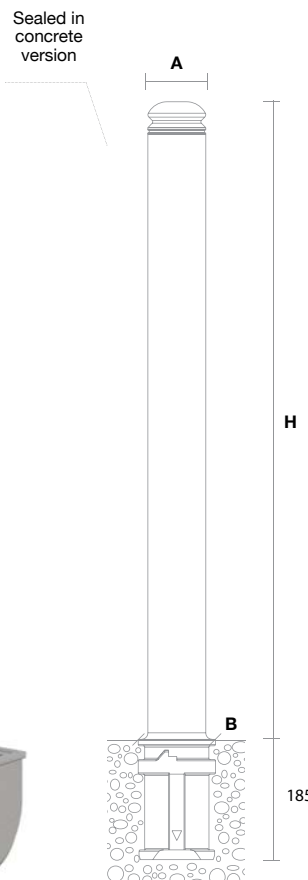

Dark grey excellence finishing
exemple (RAL 7016)



RS115 www.retention-system.com

RETENTION SYSTEM™ sockets are intelligent foundation solutions for the installation and maintenance of posts.