

T100-COCl₂ Toxic Gas Detector

- 2-wire, 4-20mA Transmitter
- Plug-in electrochemical sensor
- Built-in ZERO & SPAN controls
- One person calibration
- SMD electronic circuitry
- Enhanced RFI and EMI resistance
- Cost effective with high performance
- Works with most 4-20mA controllers
- Certified ATEX II 2 G EEx ia IIC T4 Ga

The T100-COCl₂ is a 4-20mA, 2-wire transmitter to monitor phosgene gas in the range 0-5ppm (other ranges are also available to special order). It is housed in a rugged, compact metallic enclosure. It incorporates advanced SMT electronics and an amperometric electrochemical sensor based on micro fuel cell technology, designed to be maintenance free and inherently stable.

The sensor uses the highly successful capillary diffusion barrier technology, resulting in a direct response to concentration, relatively unaffected by pressure. The use of electrodes based on fuel cell technology gives a high reserve of activity which results in long term stability.

Gas diffusing to the sensor electrode reacts at the surface of the electrode by oxidation. Reactions are catalysed by specially developed electrode materials and are designed to be specific to the gas being sensed.

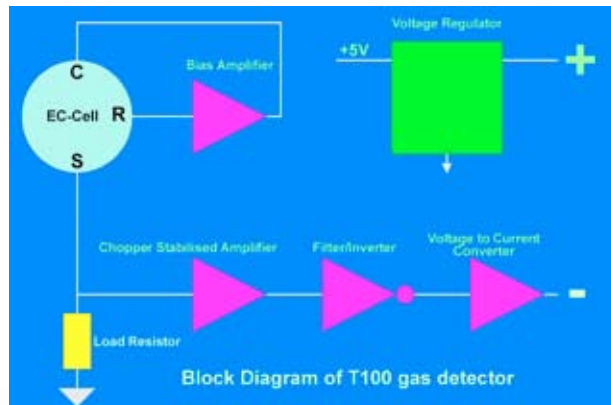

The T100 electronics use advanced surface mount technology and a simple yet rugged design to minimise component count for optimum reliability of the electronic circuitry.

The MTBF (mean time Between Failure) of the electronic circuitry on the T100 was calculated to be 1.2 million hours (calculations based on MIL-HDBK-217F). The calculations do not include the sensor as this is a consummable part.

The sensor is a small plug-in component and is easily replaced in minutes when it becomes depleted.

The sensor and preamplifier circuitry is housed in a stainless steel cylinder. This is attached to a rugged, IP67 rated, metallic enclosure which houses and protects the remaining electronics and terminals.

The T100 has been independently tested and certified ATEX II 2 G EEx ia IIC T4. With any suitable third party IS barrier, it may be installed in a Zone, Zone 1 or even Zone 0 Hazardous Area.

Careful product design and rigorous product testing combined with a stringent ISO9002 quality assurance program at Monicon's state-of-the-art manufacturing facility ensure ultimate reliability where safety matters.



T100-COCl2 Specifications

Supply voltage	Nominal 24Vdc (operates from 12Vdc to 30Vdc)
Supply current	Normal: 4mA, full-scale 20mA
Ec-cell operating life in air at S.T.P.	Typically 12 months
Ec-cell warranty	6 months
Response time (T50)	<60 seconds calculated from 3 minute exposure time
Response time (T90)	<120 seconds calculated from 3 minute exposure time
Preconditioning Requirements	1 Hour (24 hours recommended for optimum performance)
Measuring range	0-5ppm (other ranges available to special order)
Operating temperature range	-20°C to +40°C
Effect of operating temperature on sensitivity	-0.3% shift in sensitivity per 1°C temperature change from 20°C
Operating pressure range	Ambient ± 10%
Effect of operating pressure on accuracy	Pressure coefficient of 0.008% signal/mBar
Operating RH range	15% to 90% non-condensing
Effect of humidity	Abrupt change may cause transient.
Position sensitivity	None
Drift, S.T.P. continuous duty in air	<2% Full Scale per month
ATEX certification	II 2 G Ex ia IIC T4 Ga (Certificate No. Baseefa11ATEX0115X)
Size	W: 75mm, D: 58mm, H: 80mm (excluding sensor)
Weight	400g
Electromagnetic Conformance (EMC)	Complies with EN50081 and EN50082
Enclosure material	Durable aluminium ALSi12, magnesium content <0.4%, finished in stove enamel gray RAL7001. Stainless Steel sensor compartment. (Marine grade version available to special order)

Cross sensitivity to other gases

The T100-COCl2 is cross sensitive to some other gases. The following table gives an indication of cross sensitivities:

Gas	CO	H ₂ S	IPA	N ₂	HCL	O ₃	CH ₄	AsH ₃	HC	CL ₂	CO ₂	NO ₂	NH ₃
Concentration	100	5	1000	100%	10	0.25	1000	1	1000	1	5000	10	100
Response ppm	0	5 *	0	0	25	-0.03	0	1	0	0.5	0	-1	0
Temperature	20°C	20°C	20°C	20°C	20°C	20°C	20°C	20°C	20°C	20°C	20°C	20°C	20°C

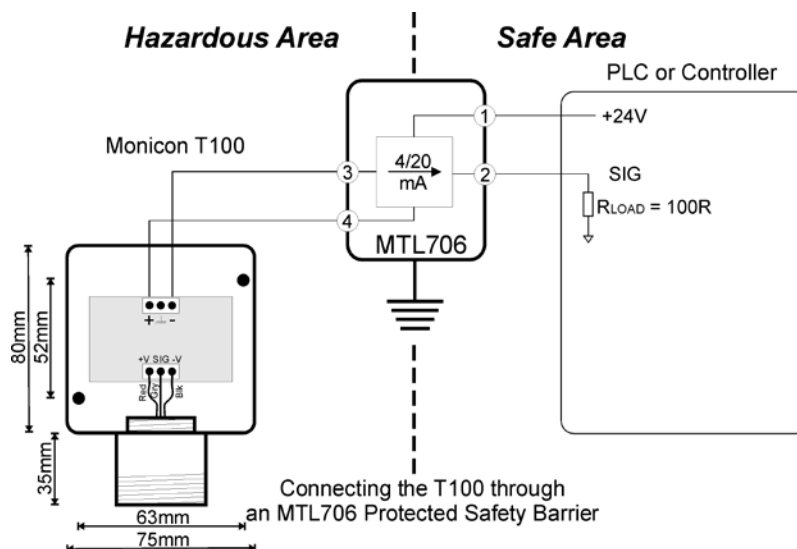

Monicon Technology Ltd
 Ballybrit Industrial Estate
 Monivea Road
 Galway
 Ireland

Tel: +353 91 752884
 Fax: +353 91 752886
 e-mail: sales@monicon.com
 web-site: www.monicon.com