

**T100-CO Toxic Gas Detector**

- 2-wire, 4-20mA Transmitter
- Plug-in electrochemical sensor
- Built-in ZERO & SPAN controls
- One person calibration
- SMD electronic circuitry
- Enhanced RFI and EMI resistance
- Cost effective with high performance
- Works with most 4-20mA controllers
- Certified ATEX II 2G Ex ia IIC T4 Ga

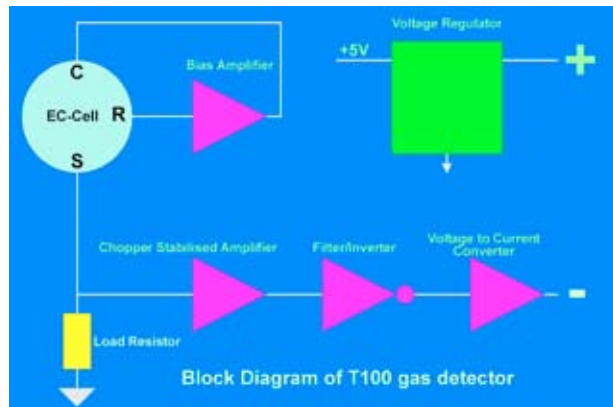

The T100-CO is a 4-20mA, 2-wire transmitter to measure a carbon monoxide gas in the range 0-50ppm, 0-100ppm, 0-250ppm and 0-1000ppm (0-1% available to order) It is housed in a rugged, compact metallic enclosure. It incorporates advanced SMT electronics and an amperometric electrochemical sensor based on micro fuel cell technology, designed to be maintenance free and inherently stable.

The sensor uses the highly successful capillary diffusion barrier technology, resulting in a direct response to concentration, relatively unaffected by pressure. The use of electrodes based on fuel cell technology gives a high reserve of activity which results in long term stability.

Gas diffusing to the sensor electrode reacts at the surface of the electrode by oxidation. Reactions are catalysed by specially developed electrode materials and are designed to be specific to the gas being sensed.



The T100 electronics use advanced surface mount technology and a simple yet rugged design to minimise component count for optimum reliability of the electronic circuitry.

The MTBF (mean time Between Failure) of the electronic circuitry on the T100 was calculated to be 1.2 million hours (calculations based on MIL-HDBK-217F). The calculations do not include the sensor as this is a consummable part.

The sensor is a small plug-in component and is easily replaced in minutes when it becomes depleted.

The sensor and preamplifier circuitry is housed in a stainless steel cylinder. This is attached to a rugged, IP67 rated, metallic enclosure which houses and protects the remaining electronics and terminals.

The T100 has been independently tested and certified ATEX II 2G Ex ia IIC T4 Ga. With any suitable third party IS barrier, it may be installed in a Zone, Zone 1 or even Zone 0 Hazardous Area.

Careful product design and rigorous product testing combined with a stringent ISO9002 quality assurance program at Monicon's state-of-the-art manufacturing facility ensure ultimate reliability where safety matters.

# T100-CO Specifications

|  |   |
|--|---|
| Supply voltage                                 | Nominal 24Vdc (operates from 12Vdc to 30Vdc)  |
| Supply current                                 | Normal: 4mA, full-scale 20mA  |
| Ec-cell operating life in air at S.T.P.        | Typically 24 months   |
| Ec-cell warranty                               | 12 months   |
| Response time (T50)                            | <15 seconds calculated from 4 minute exposure time  |
| Response time (T90)                            | <25 seconds calculated from 4 minute exposure time  |
| Preconditioning Requirements                   | 1 Hour (24 hours recommended for optimum performance)   |
| Measuring range                                | 0-50ppm, 0-100ppm, 0-250ppm, 0-1000ppm (0-1% to order)  |
| Operating temperature range                    | -20°C to +40°C (-20°C to +50°C in non-hazardous areas)  |
| Effect of operating temperature on sensitivity | -0.3% shift in sensitivity per 1°C temperature change from 20°C   |
| Operating pressure range                       | Ambient ± 10%   |
| Effect of operating pressure on accuracy       | Pressure coefficient of 0.008% signal/mBar  |
| Operating RH range                             | 15% to 90% non-condensing   |
| Effect of humidity                             | Abrupt change may cause transient.  |
| Position sensitivity                           | None  |
| Drift, S.T.P. continuous duty in air           | <2% Full Scale per month  |
| ATEX certification                             | II 2G Ex ia IIC T4 Ga (Certificate No. Baseefa11ATEX0115X)  |
| Size   | W: 75mm, D: 58mm, H: 80mm (excluding sensor)  |
| Weight   | 400g  |
| Electromagnetic Conformance (EMC)              | Complies with EN50081 and EN50082   |
| Enclosure material                             | Durable aluminium ALSi12, magnesium content <0.4%, finished in stove enamel gray RAL7001. Stainless Steel sensor compartment. (Marine grade version available to special order) |

## Cross sensitivity to other gases

The T100-CO is cross sensitive to some other gases. The following table gives an indication of cross sensitivities:

| Gas           | CO   | H <sub>2</sub> S | SO <sub>2</sub> | N <sub>2</sub> | HCL  | H <sub>2</sub> | HCN  | PH <sub>3</sub> | HC   | CL <sub>2</sub> | CO <sub>2</sub> | C <sub>2</sub> H <sub>4</sub> | NH <sub>3</sub> |
|---------------|------|------------------|-----------------|----------------|------|----------------|------|-----------------|------|-----------------|-----------------|-------------------------------|-----------------|
| Concentration | 100  | 15               | 10              | 100%           | 5    | 100            | 10   | 10              | 1000 | 1               | 5000            | 100                           | 10              |
| Response ppm  | 100  | 38               | 6               | 0              | 0    | 60             | 5    | 33              | 0    | -0.5            | 0               | 0                             | 0               |
| Temperature   | 20°C | 20°C             | 20°C            | 20°C           | 20°C | 20°C           | 20°C | 20°C            | 20°C | 20°C            | 20°C            | 20°C                          | 20°C            |

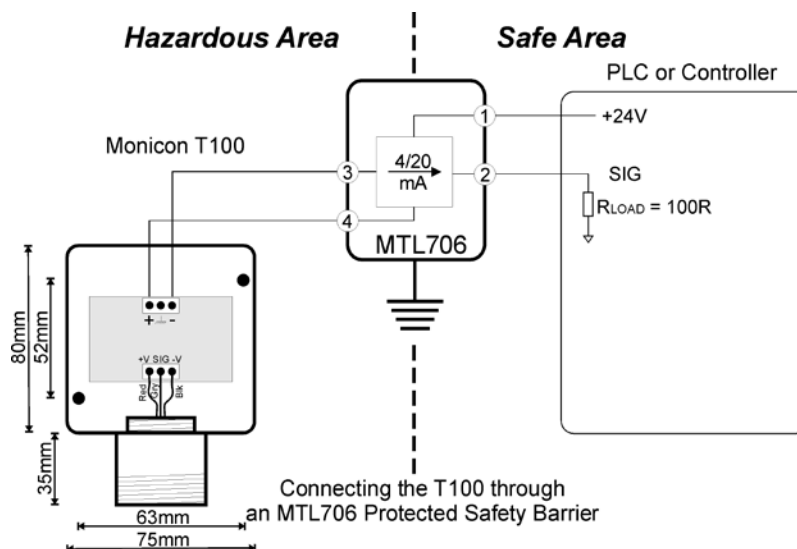

**Monicon Technology Ltd**  
**Ballybrit Industrial Estate**  
**Monivea Road**  
**Galway**  
**Ireland**

Tel: +353 91 752884  
 Fax: +353 91 752886  
 e-mail: sales@monicon.com  
 web-site: www.monicon.com