

SMART JOINT

SMART SERIES FLANGE ADAPTORS WITH END RESTRAINT SYSTEM

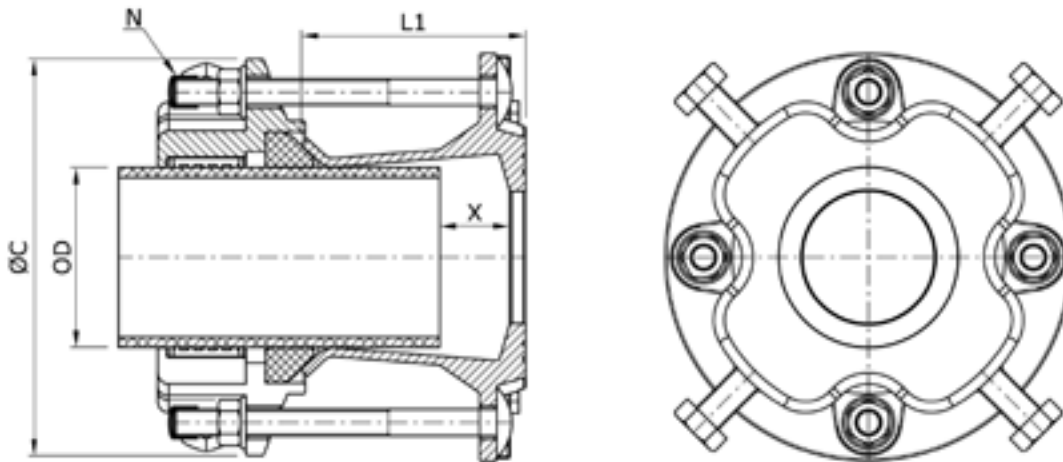

DN	ØD		L1	ØC	Bolts Quantity	Gap X		Type Of Flange	Weight
	Min.	Max.				Max	Min.		
50	58	74	170	170	4	70	40	a,b,c,d	6,22
50/65	68	84		183				a,b,c,d	7,2
80	84	105		210				a,b,c,d	8,26
100	99	118		223				a,b,c,d	8,96
	109	133	244	a,b,c,d	10,32				
125/150	133	157	190	268	6	80	35	a,b,c,d	13,46
150	157	182		296				a,b,d	13,72
200	194	215		322				a,b,d	16,88
	218	242		354		a,b	18,48		
250	242	268		403		a,b	23,92		
	266	291		405		a,b	30,18		
300	280	305	424	a,b	33,5				
	302	327	443	a,b,d	35,34				

The data concerning the min. and max. gap is calculated on the minimum outside diameter of the product's range

NOVA SIRIA end restraint fittings are suitable for the following pipes: steel, ci/DI, PE, pressure PVC.

All end restraint fittings installed on pe Or pressure PVC Pipes must be integrated with an internal reinforcing liner provided or approved by noVA SIRIA.

FOR FLANGED VERSION

- a. EN1092 PN10, PN16
- b. ANSI B16. CL125
- c. BS 10 TABLE D
- d. BS 10 TABLE E

NOTES

