

MULTIGRIP MGR-S PN16

SINGLE BOLT COUPLING

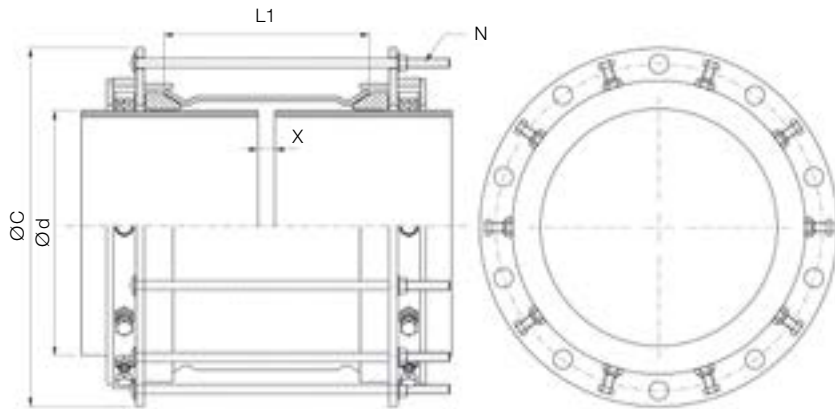

PN 16 RATED HYDRAULIC SEALING AND END RESTRAINT SYSTEM

Other sizes or ranges on request

DN	Ød		L1	Max. External Dimension ØC	Compression Bolts	Gap X		Weight
	Min.	Max.			Quantity N	Max.	Min.	
350	340	370	355	560	9	220	25	119
	360	390		580				124
400	385	415		600				130
	415	445		640				139
450	440	470		660	12			153
	465	495		680				159
500	490	520		720				166
	515	545		740				173
	545	575		788	181			
600	595	625		808	15			192
	615	645		828				197
700	695	725		908	18			235
	720	750		933				245
800	785	815		998				262
	795	825		1008				265
	825	855		1038	285			
900	885	915	1098	20	301			
	900	930	1113		305			
1000	930	960	1143		345			
	985	1015	1198		361			
	1000	1030	1213	366				
1100	1030	1060	1243	22	380			
	1100	1130	1313		-			
	1135	1165	1348		-			
1200	1185	1215	1398	24	-			
	1205	1235	1418		-			
	1240	1270	1453		-			
1400	1385	1415	1598	30	-			
	1405	1435	1618		-			
	1445	1475	1658		32	-		

The data concerning the min. and max. gap is calculated on the minimum outside diameter of the product's range. This chart is for indicative purposes. Nova Siria srl can vary the indicated standards (tolerance range, dimensions and materials) according to specifications requested by Customers or to designing needs. NOVA SIRIA end restraint fittings are suitable for the following pipes: steel, ci/DI, PE, pressure PVC. All end restraint fittings installed on pe Or pressure PVC Pipes must be integrated with an internal reinforcing liner provided or approved by noVA SIRIA.