

MULTIGRIP MGR-D

DOUBLE BOLT COUPLING

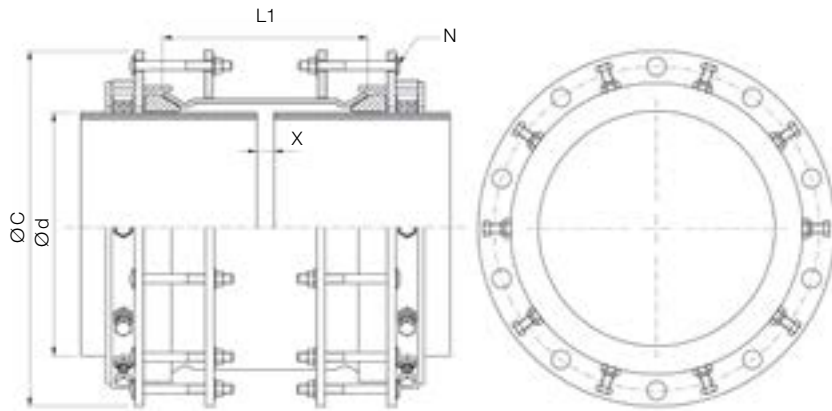

PN 16 RATED HYDRAULIC SEALING AND END RESTRAINT SYSTEM

Other sizes or ranges on request

DN	Ød		L1	Max. External Dimension ØC	Compression Bolts Quantity N	Gap X		Weight	
	Min.	Max.				Max.	Min.		
350	340	370	355	560	18	220	25	156	
	360	390		580				163	
400	385	415		600				172	
	415	445		640				182	
450	440	470		660	24			199	
	465	495		680				207	
500	490	520		720				28	216
	515	545		740					225
560	545	575		788	30			228	
600	595	625		808				36	244
	615	645		828	250				
700	695	725		908	40			295	
	720	750		933				307	
800	785	815		998				44	329
	795	825		1008					332
	825	855		1038	355				
900	885	915		1098	48			376	
	900	930		1113				381	
1000	930	960	1143	60	425				
	985	1015	1198		446				
	1000	1030	1213		451				
1100	1030	1060	1243	64	465				
	1100	1130	1313		-				
	1135	1165	1348		-				
1200	1185	1215	1398	-	-				
	1205	1235	1418		-				
	1240	1270	1453		-				
1400	1385	1415	1598	-	-				
	1405	1435	1618		-				
	1445	1475	1658		-				

The data concerning the min. and max. gap is calculated on the minimum outside diameter of the product's range

This chart is for indicative purposes. Nova Siria srl can vary the indicated standards (tolerance range, dimensions and materials) according to specifications requested by Customers or to designing needs.

NOVA SIRIA end restraint fittings are suitable for the following pipes: steel, ci/DI, PE, pressure PVC.

All end restraint fittings installed on pe Or pressure PVC Pipes must be integrated with an internal reinforcing liner provided or approved by noVA SIRIA.