

**Page  
M 2**

## Extension spindles

Rigid or telescopic

Page M 2/1



**Page  
M 3**

## Surface boxes & base plates

Telescopic made of plastic  
Rigid made of ductile iron  
Telescopic made of ductile iron  
Height adjustable DIN rated Surface box  
Base plates made of recycled plastic

Page M 3/1  
Page M 3/3  
Page M 3/4  
Page M 3/5  
Page M 3/7

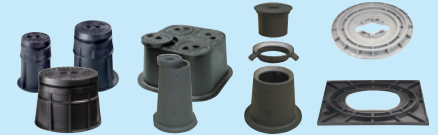

**Page  
M 4**

## Valve accessories

Page M 4/1



**Page  
M 5**

## HAWAK-pillar

For above ground operation of valve

Page M 5/1



**Page  
M 6**

## Hydrant accessories

Page M 6/1



## Support liners

For PE pipes

Page M 6/2

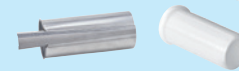

**Page  
M 7**

## Accessories

Page M 7/1

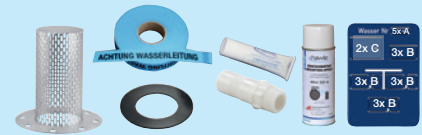

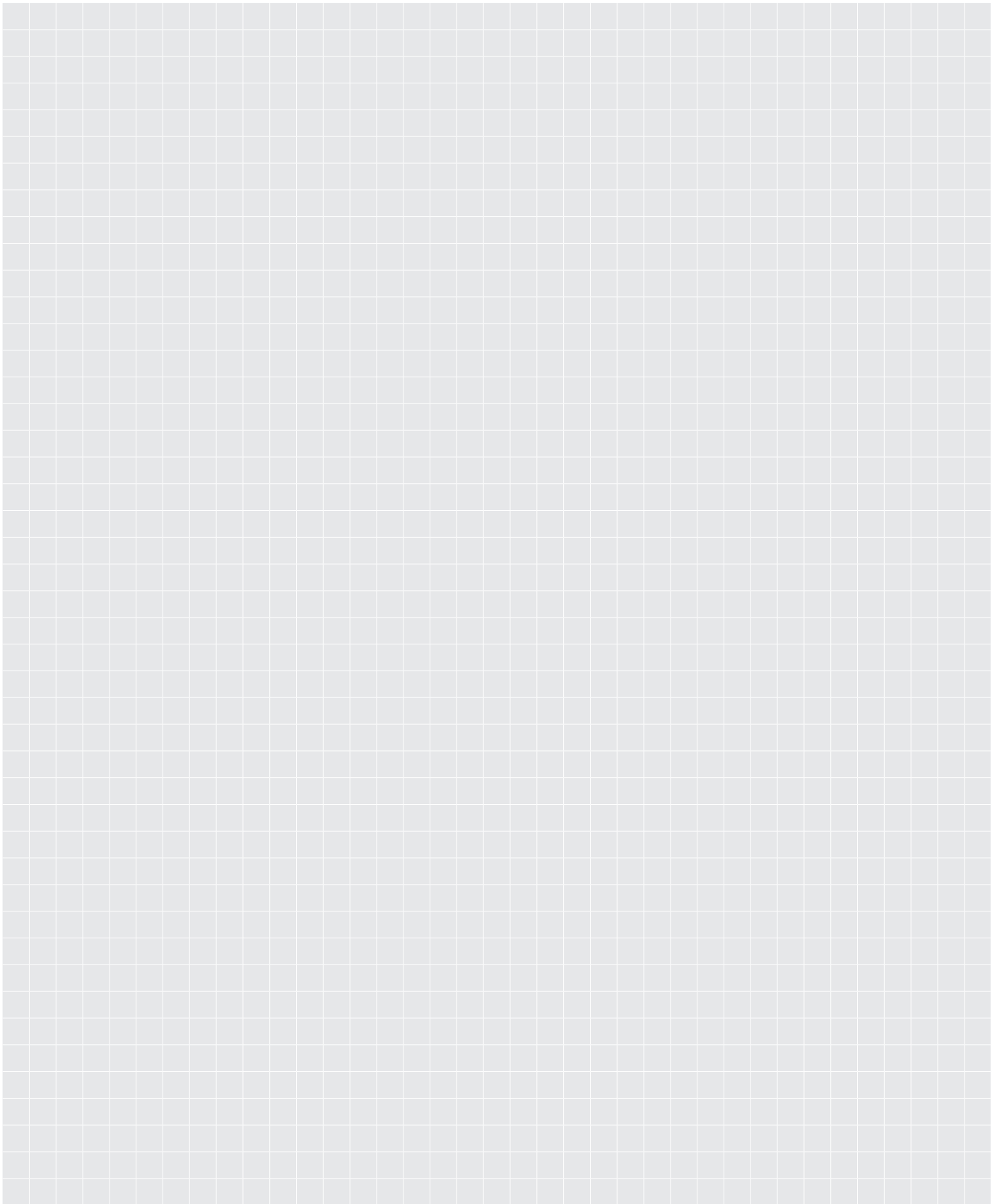

# EXTENSION SPINDLE

Rigid or telescopic



## Design features

- One extension spindle for several dimensions
- Protective cover with integrated locking mechanism
- No additional fixing (bolt/pin) necessary
- DN 50 to 200

Order No.	Version	Pipe cover (RD)	Dimension/DN		
			50/65/80/100	125/150	200
9000E2	rigid	1,00 m			
		1,25 m			
		1,50 m			
		2,00 m			
		2,50 m			
9500E2	telescopic	1,30 - 1,80 m			
		1,35 - 1,80 m			
		2,00 - 2,50 m			
		2,50 - 3,50 m			

## Suitable accessories

- **Extender for rigid spindle**  
**Order no. 7830** price for first meter  
**Order no. 7831** price for each additional half meter
- Please specify dimensions and length when ordering

## Design features

- Attachment of the extension spindle to the valve spindle takes place with a stainless steel splint
- DN 250 to 600

Order No.	Version	Pipe cover (RD)	Dimension/DN					
			250	300	350	400-500*	500	600
9000E2	rigid	1,00 m						
		1,25 m						
		1,50 m						
		1,90 m						
		2,00 m						
		2,40 m						
		2,50 m						
9500E2	telescopic	1,40 - 1,80 m						
		1,50 - 1,80 m						
		1,90 - 2,20 m						
		2,00 - 2,30 m						
		2,00 - 2,50 m						
		2,50 - 3,50 m						

\* Body DN 400, with flange connection DN 450 or 500

## For E2 valves and E2 Combi valves DN 50-200

**No. 9000E2**

Rigid

**No. 9500E2**

Telescopic



## For E2 valve DN 250-600

**No. 9000E2**

Rigid

**No. 9500E2**

Telescopic



# EXTENSION SPINDLES

Rigid or telescopic



## No. 9000E2 / 9500E2

All extension spindles (rigid or telescopic) of all types and dimensions are protected against dirt and surface water.

The telescopic extension spindle can be progressively adjusted to ground level. This is done by pushing or pulling the tube and the spindle shaft.

The telescopic effect protects the pipe and fitting from surface impact.

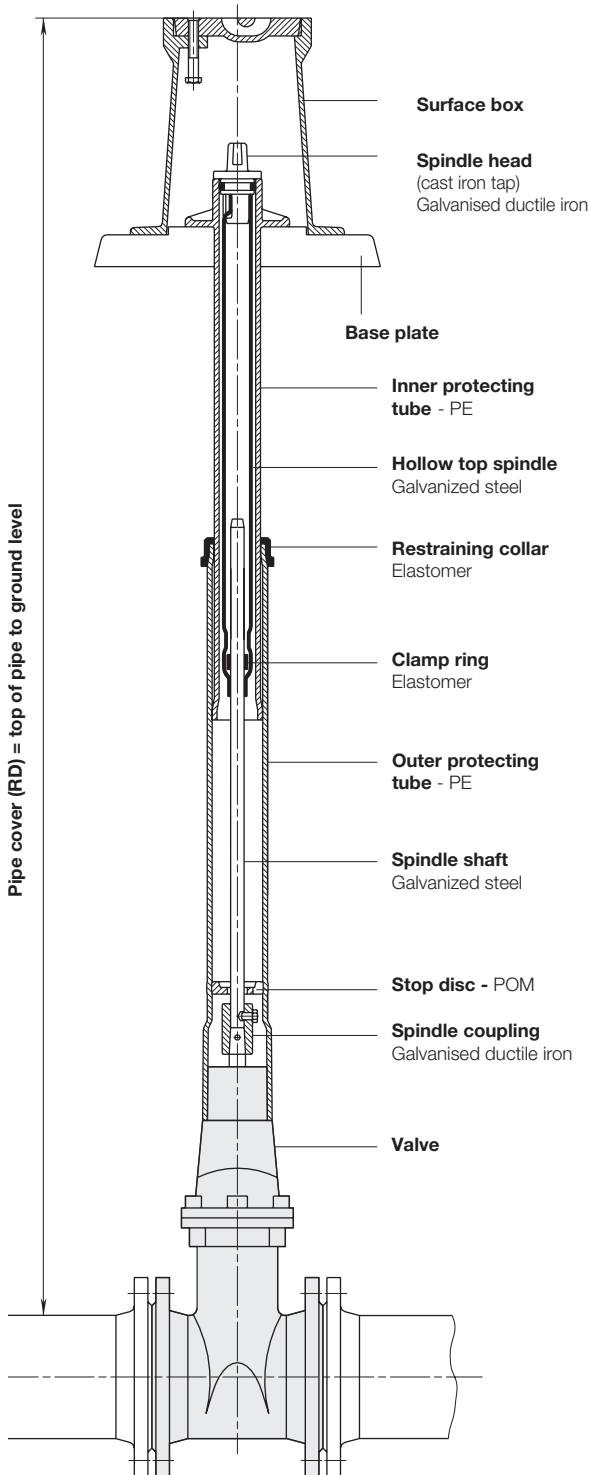
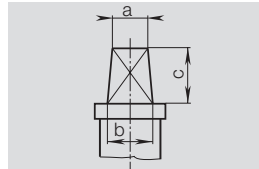

Illustration: 9500E2 DN 250-600

### Spindle head | square



For service valves	a 13 mm b 15 mm c 24 mm
For valves and combi valves	a 27 mm b 32 mm c 48 mm

9000E2	Weights extension spindles, rigid - DN								
Pipe cover (RD)	50/65/80/100	125/150	200	250	300	350	400-500	500	600
1,00 m	3,50	2,80	2,70	3,10	3,00				
1,25 m	4,50	3,70	3,50	4,70	4,30	4,20	3,55		
1,50 m	5,50	4,80	4,50	6,00	5,80	5,40	5,00		
1,90 m								7,40	
2,00 m	7,45	6,60	6,50	9,00	8,70	8,45	7,80		7,40
2,40 m								7,40	
2,50 m	9,40	8,60	8,50	12,20	12,00				7,40

9500E2	Weights extension spindles, telescopic - DN								
Pipe cover (RD)	50/65/80/100	125/150	200	250	300	350	400-500*	500	600
1,30 - 1,80 m	6,60	6,25							
1,35 - 1,80 m			6,10						
1,40 - 1,80 m				7,30					
1,50 - 1,80 m					6,90	6,70	6,30		
1,90 - 2,20 m								8,80	
2,00 - 2,30 m									8,80
2,00 - 2,50 m	9,50	8,90	8,60	11,00	10,50	10,20	9,70		
2,50 - 3,50 m	12,80	12,00	11,90	15,30	14,90	14,50	14,20		
2,60 - 3,50 m								14,50	14,00

\* Body DN 400, with flange connection DN 450 or 500

### Assembly instructions

Fig.: Assembly E2 extension spindle DN 50-200

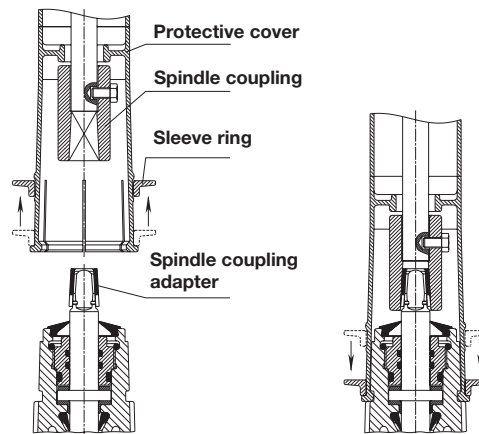

# EXTENSION SPINDLES

Rigid or telescopic



## Design features

- One extension spindle for several dimensions
- Threaded connection for attachment to the service valve
- No additional fixing (bolt/pin) necessary

Order No.	Version	Pipe cover (RD)	¾" - 2"
9101	rigid	0,75 m	
		1,00 m	
		1,25 m	
		1,50 m	
		2,00 m	
		2,50 m	
9601	telescopic	0,60 - 0,80 m	
		0,80 - 1,20 m	
		1,00 - 1,60 m	
		1,30 - 1,80 m	
		2,00 - 2,50 m	
		2,50 - 3,50 m	

## Suitable accessories

- **Extender for rigid spindle**  
**Order no. 7830** price for first meter  
**Order no. 7831** price for each additional half meter
- Please specify dimensions and length when ordering

## Design features

- Can be located by metal detectors
- Attachment to the valve takes place with a pin through the spindle square

			Hawle-A	Elypso 50-80	Hawle-A + Elypso		Hawle-A
			50/65	Hawle-A 80	100/125	150	200
9000A		1,00 m					
		1,50 m					
9500A		0,90 - 1,15 m					
		1,30 - 1,80 m					
		1,35 - 1,80 m					
		1,40 - 1,80 m					
		1,80 - 2,50 m					
		2,00 - 2,50 m					
		2,50 - 3,50 m					

## Extension spindle for service valves with threaded connection for spindle DN ¾" – 2"

**No. 9101**

Rigid

**No. 9601**

Telescopic

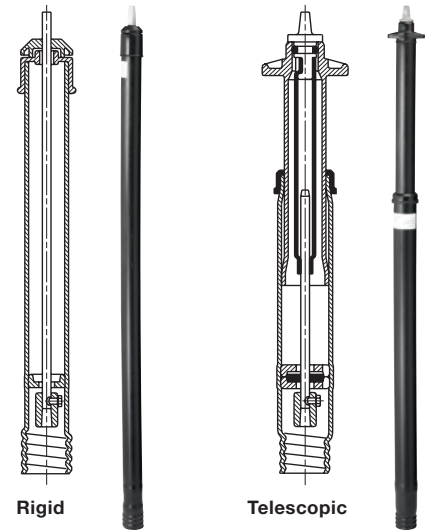

Rigid

Telescopic

## Extension spindle for Hawle-A valves and Elypso valves DN 50-300

**No. 9000A**

Rigid

**No. 9500A**

Telescopic



Rigid

Telescopic

Rigid

Telescopic

Rigid

Telescopic

DN 50/65  
Hawle-A

DN 50/200  
DN 50 - 200 Elypso  
80 - 200 Hawle-A

DN 250 - 300  
Hawle-A

# EXTENSION SPINDLES

Rigid or telescopic



No. 9101 / 9601  
No. 9000A / 9500A

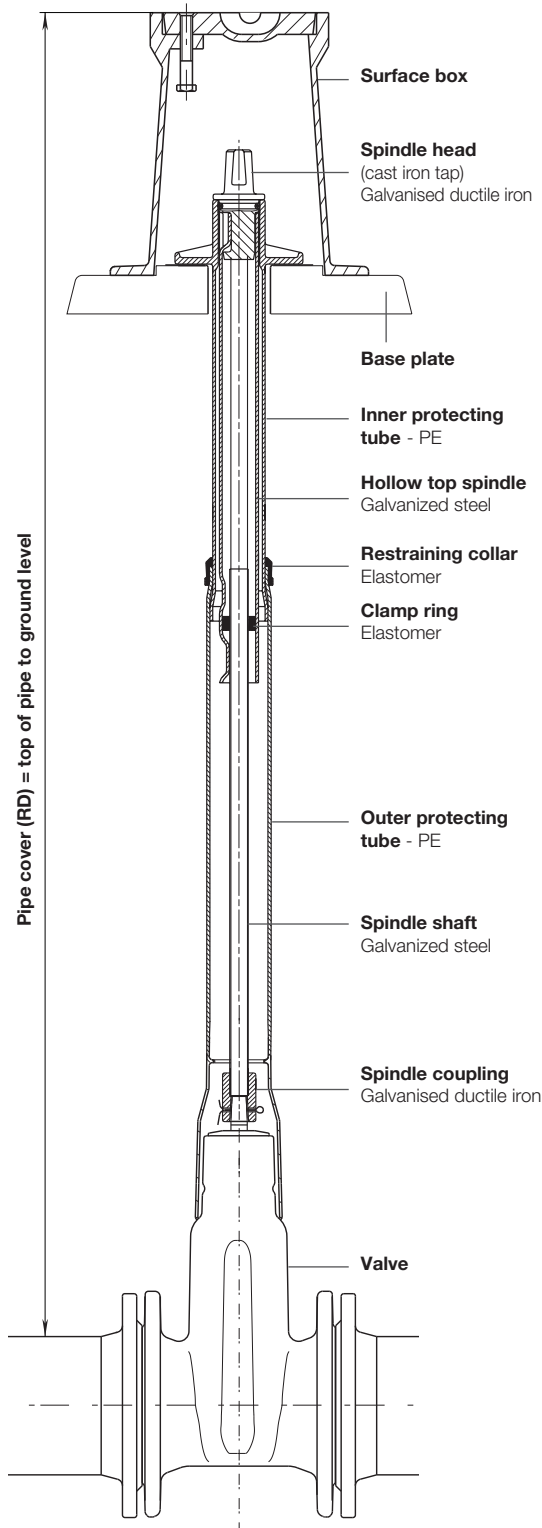
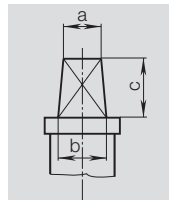

Illustration: Hawle-A extension spindle "telescopic", DN 80-200

All extension spindle dimensions and types (rigid or telescopic) are protected against dirt and surface water.

The telescopic extension spindle can be progressively adjusted to ground level. This is done by pushing or pulling the protecting tube and the spindle shaft. The telescopic effect protects the pipe and fitting from surface impact.

## Spindle head | square



For service valves	Version rigid/telescopic	a 13 mm b 15 mm c 24 mm
For gate valves	Version telescopic	a 27 mm b 32 mm c 48 mm
	Version "rigid"	30 mm

## Weight of extension spindle with threaded connection for service valves

Order No.	9101					9601						
Length m	0,75	1,00	1,25	1,50	2,00	2,50	0,6-0,80	0,8-1,2	1,0-1,6	1,3-1,8	2-2,5	2,5-3,5
Weight	1,10	1,60	2,10	2,60	3,70	4,60	1,60	2,40	3,20	3,50	4,90	6,90

## Weight of extension spindle for Hawle-A and Elypso-Valves

Version	Order No.	Pipe cover (RD)	Dimension/DN
rigid			
telescopic			

## 9000A / 9500A assembly instructions

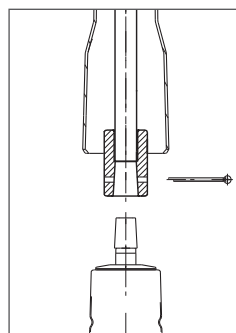

Slide back outer protecting tube, remove split pin

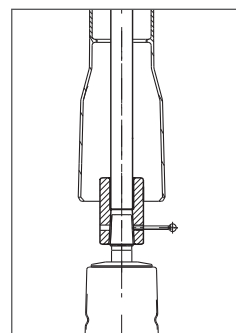

Place extension spindle shaft over valve spindle

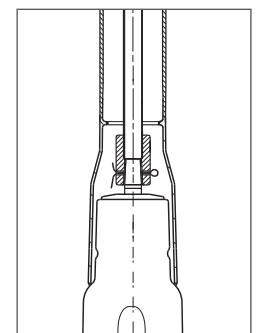

Slide outer protecting tube over gate valve housing

# SURFACE BOX

## "Telescopic" made of plastic



### Design features

- Adjustable height enables fixation of street cover at the desired level
- Cap remains standing on the road surface during work
- 4° Angular offset possible, depending on level of extension
- Less hands on work during road construction
- Homogenous connection with the tarmac, minimizing frost damage
- Quiet, no rattling of street cover
- Low maintenance (no rust problems, application of grease not necessary)
- Low weight
- No loose parts
- High stability, pressure load according to DIN 3580
- Extremely durable glass fibre construction
- Temperature invariant between: -20°C up to 245°C
- DVGW certified

Accessories: see overleaf

### Material | Technical features

- **Coverlid** made of grey cast iron, bituminised
- **Surface box body** made of polyamide 66 with 30% fibre glass
- **Safety pin** made of stainless steel

Order No.	Version	Weight	
1851K	For service valves DIN 4057	4,3	
2051K	For gate valves, DIN 4056	6,8	
1950K	For below ground hydrants DIN 4055	17,8	

## Progressively height adjustable

### No. 1851K

Symbol photo



### No. 2051K

Symbol photo



### No. 1950K



# SURFACE BOX

"Telescopic" made of plastic



## Assembly instructions

### New road construction

#### Warning:

To avoid damage, surface boxes must be installed only after laying the gravel

- Lay and compact the gravel
- Position and align the surface box
- Mark location of surface box at the roadside
- Spray the surface box with a releasing agent
- Lay the bitumen binder on the ground
- Pull the surface box top approximately 2 cm above the ground and fill the surrounding base space with tarmac.
- Clean and free the surface box cover from all foreign material

### Replace wearing surface

- Mark position of the surface box body at the roadside, spray box with a releasing agent
- Apply the tarmac layer
- Pull the surface box approximately 2 cm above the final tarmac layer. Fill the space with tarmac
- Clean cover of surface box from all foreign material
- Roll the tarmac surrounding the surface box
- Immediately loosen and clean the surface box and cap

## Suitable accessories

- **Base plate** made of recycled-plastic

Robust and stable  
Easy assembly  
Low weight  
Non-degradable

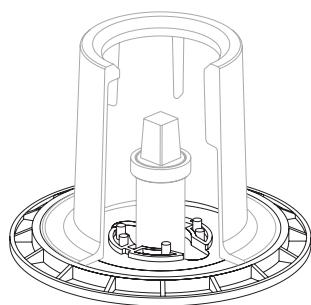

Order No.	Suitable for surface box acc. to	Weight
3481	Valve DIN 4056 and service valves DIN 4057	0,6
3482	DIN 4055 for below ground hydrants	2,0

see page M 3/7

## No. 1851K

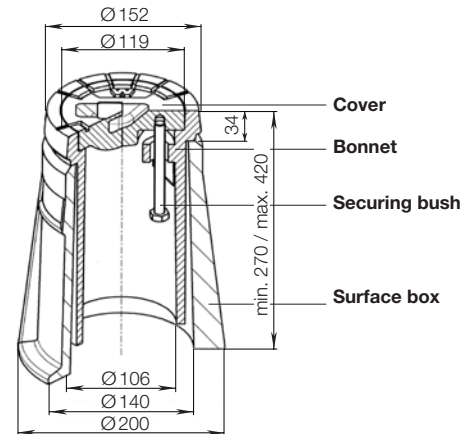

## No. 2051K

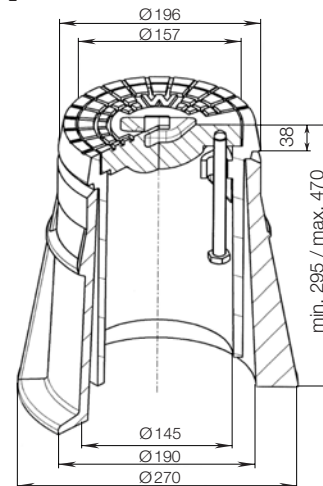

## No. 1950K

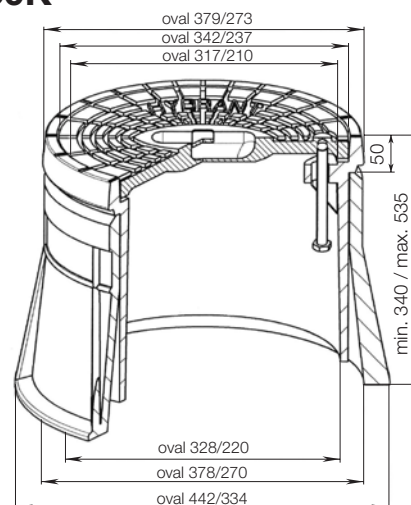



# SURFACE BOX

## "Rigid", of ductile iron



Order No.	Model for	Version	Material	Weight
1550	Service valves	light*	Bitumen coated cast grey iron	3,4
1650		heavy		6,5
1750	Valve and Combi-T			11,9
1950	Below ground hydrants			27,8
1790	Air-release hydrants			41,5
4550	Combi-III and Combi-IV	DN 80+	Bitumen coated ductile iron	34,0
		DN 100-200++		54,5

+ E-version DN 80-150, E2-version DN 80; ++ E-version DN 200, E2-version DN 100-200

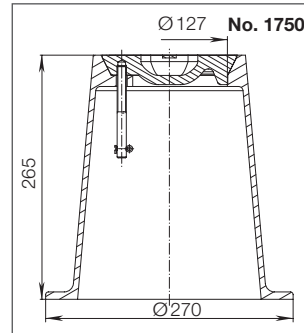
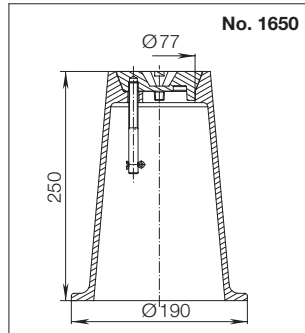
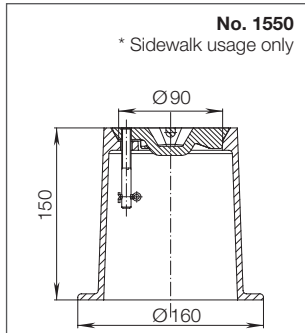

**No. 1750**

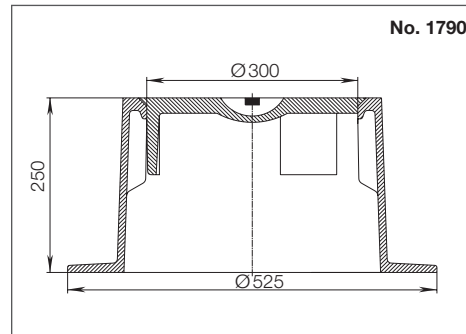
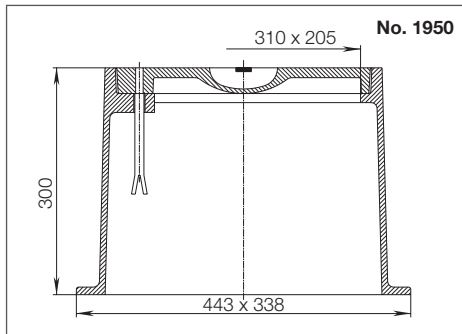

**No. 1950**

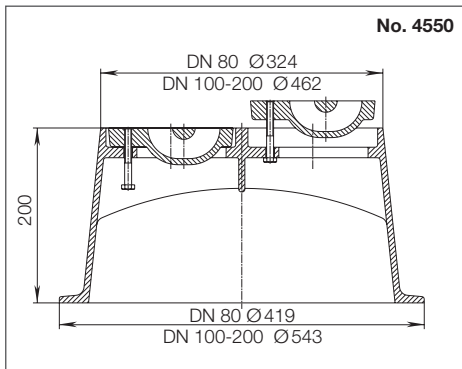

Max. load 200 kN  
(excluding No. 1550)

**No. 4450**



### Suitable accessories

#### • Conversion rings

These rings are used to adapt non adjustable surface boxes already installed to HAWLE adjustable types.

Order No.	For surface box	Material	Weight
1560	No. 1550	Bitumen coated cast grey iron	0,90
1660	No. 1650		0,90
1760	No. 1750		2,45

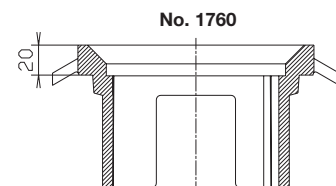
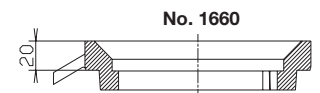
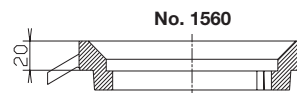

# SURFACE BOX

## "Telescopic", of ductile iron



Order No.	Model for:	Version	Material	Weight
1850	Service valves	Complete box, without extension rings	Bitumen coated grey iron	7,0
2050	Valves und Combi-T			12,2

Height adjustable Surface Box to DIN see page M 3/5

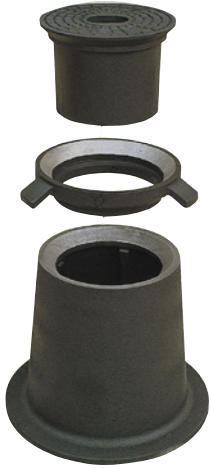

Max. load 200 kN

### Surface box telescopic

**with extension rings to adjust to ground level!**

The cylindrical guide combined with machined conical seating results in tight and noiseless fitting of the lid.

The design enables the lid to be easily removed.

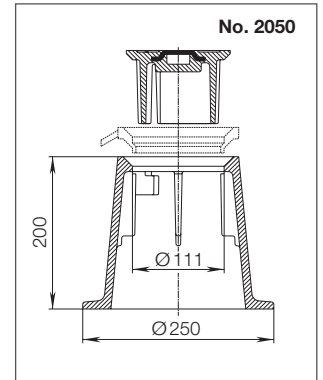
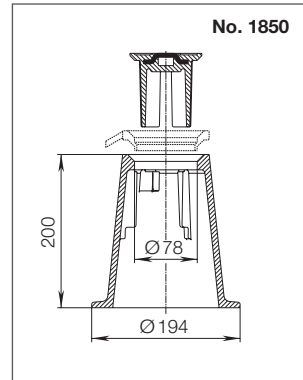

#### Suitable accessories | Spare parts

- Lid for adjustable surface boxes** of bitumen coated grey iron

Order No.	For surface box	Weight
1860	No. 1850	1,30
2060	No. 2050	2,65

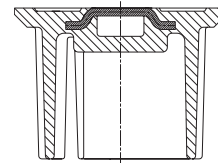

- Extension rings** of bitumen coated grey iron adjusting to ground level with extension ring

Order No.	For tele surface box	High Weight					
		12	15	20	30	40	50
2030	No. 1850	0,50	0,70	0,90	1,10	1,50	1,20
2040	No. 2050		1,00	1,40	2,00	2,70	3,50

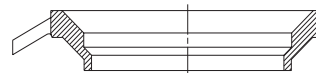

- Base plate** of stamped, galvanized sheet steel  
Measurement: 360 mm x 360 mm

Order No.	For surface box	Weight
3480	No. 1550, 1650, 1850	1,70
3490	No. 1750, 2050	1,70

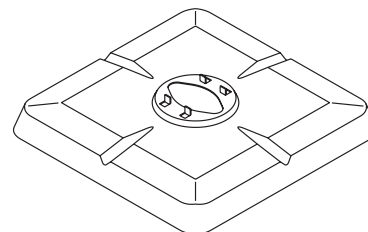

# Height adjustable DIN rated SURFACE BOX

With separate removable mounting ring for road surfaces which have to be milled down



## Design features

- Proven angle seat prevents the cover from rattling
- High quality corrosion protection using the GSK fluidised bed epoxy coating system
- The removable mounting ring enables a milling down of the road surface without removing the surface box.
- Height adjustable with extension rings
- Cover secured by stainless steel retaining rod
- Available on request: extension ring for sloping roads (see illustration 1)

## Material | Technical features

- **Cover** made of gray cast iron, epoxy powder coating
- **Retaining rod and cover neck** of stainless steel
- **Turned angle seats** are processed

## Surface box

Order No.	Version	Weight	
2051	DIN 4056 (gate valves)	21,5	
1851	DIN 4057 (service valves)	11,0	

## Extension rings

Order No.	For surface box	Height Weight			
		10	20	30	50
2045	No. 2051	0,9	1,2	1,6	2,7
2035	No. 1851	0,4	0,8	1,2	2,0

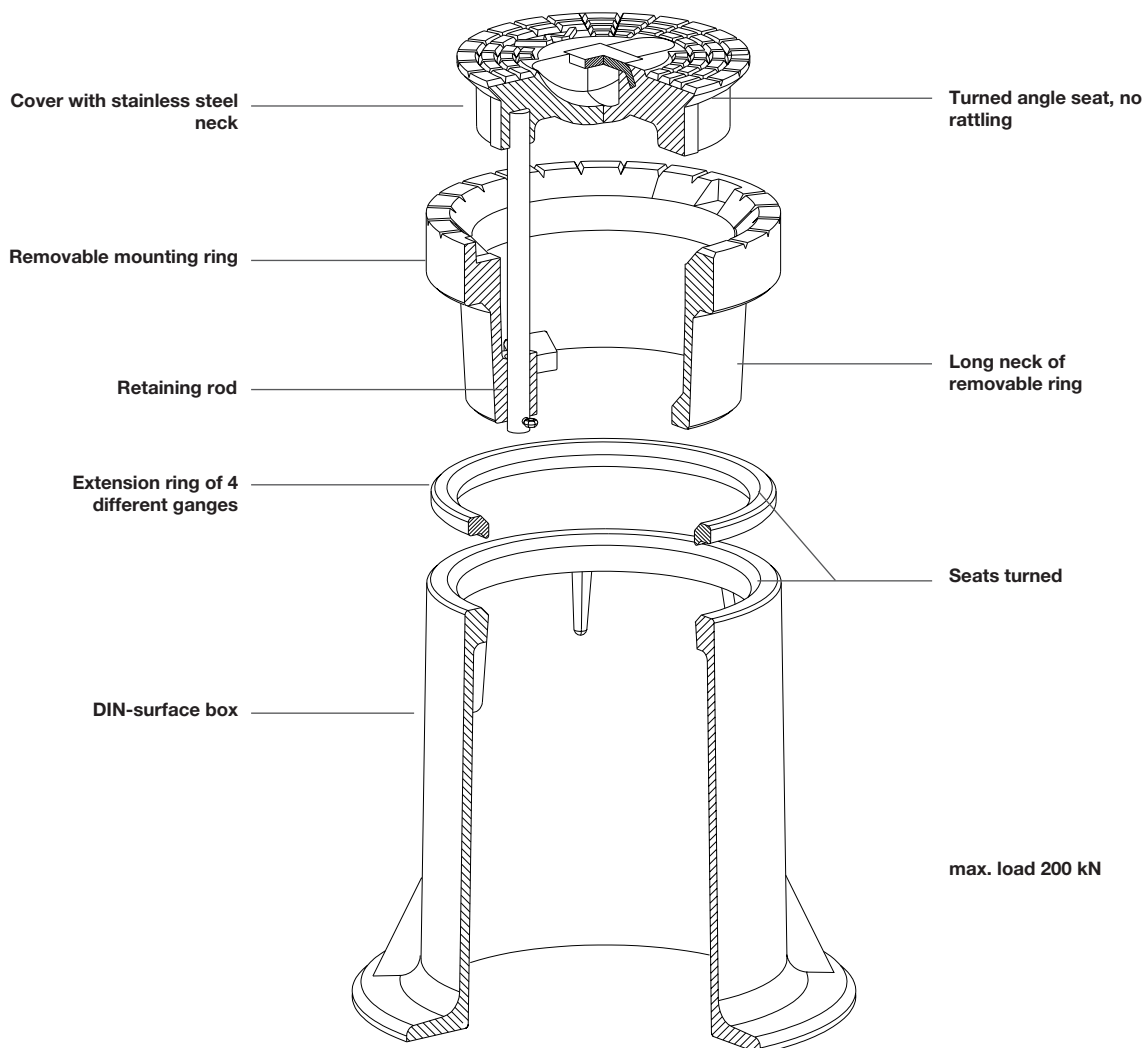

# Height adjustable DIN rated SURFACE BOX

With separate removable mounting ring for road surfaces which have to be milled down



## Dimensions for DIN surface boxes

a = DIN 4056    b = DIN 4057

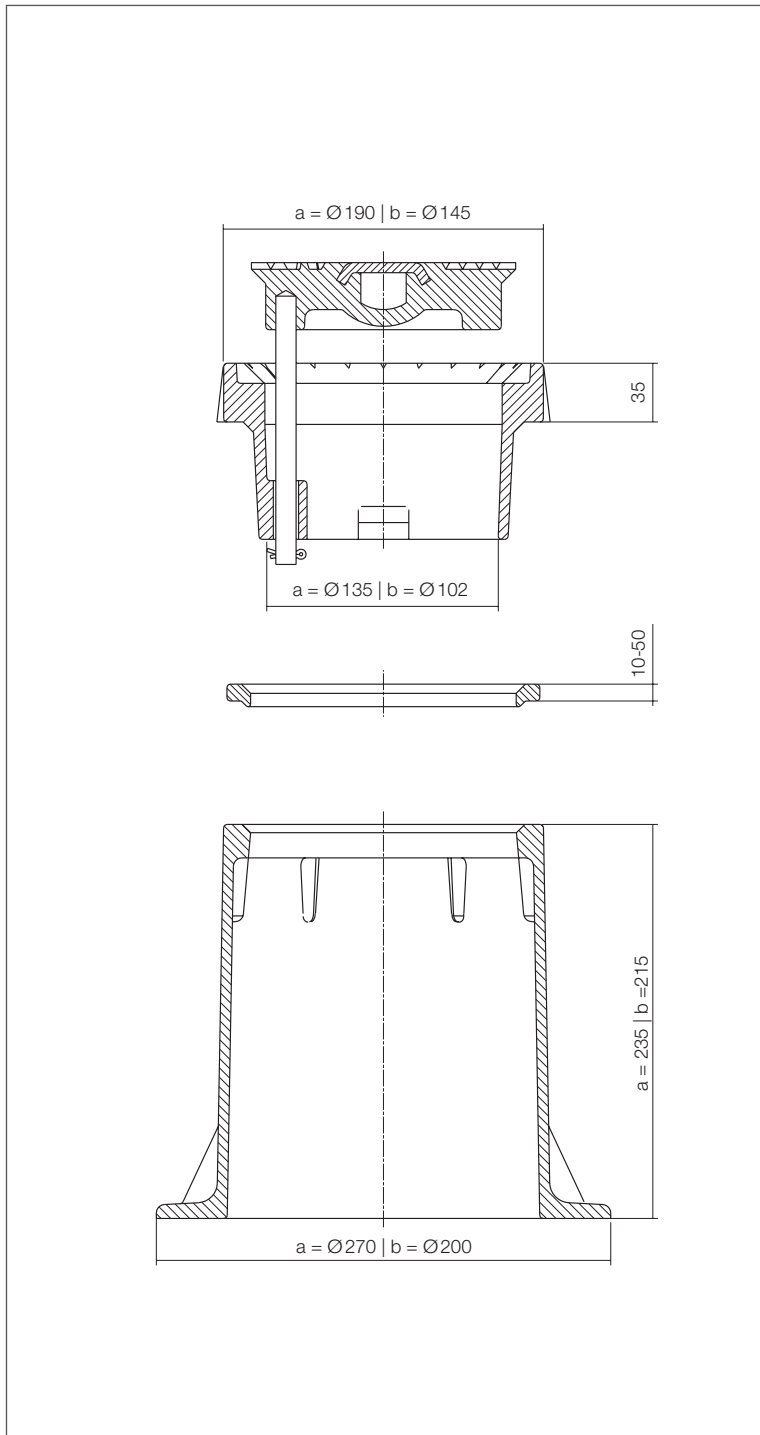

## Extension ring for sloping roads

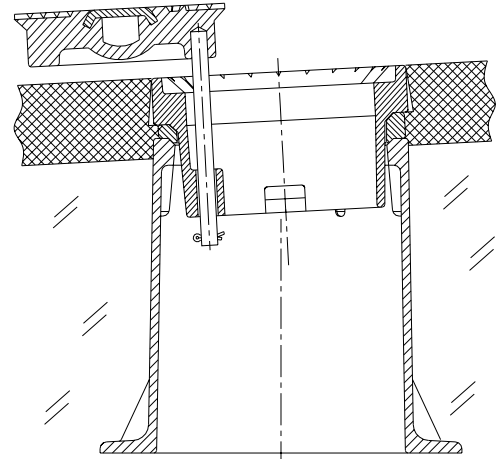

Illustrationn 1

# BASE PLATES FOR SURFACE BOXES

Made of recycled plastic



## Design features

- Unbreakable and solid
- Easy assembly
- Low weight
- Durable, non-degradable

Order No.	Suitable for surface boxes acc. to	Weight	
3481	DIN 4056, DIN 4057	0,6	
3482	DIN 4055	2,0	

Installation situation:

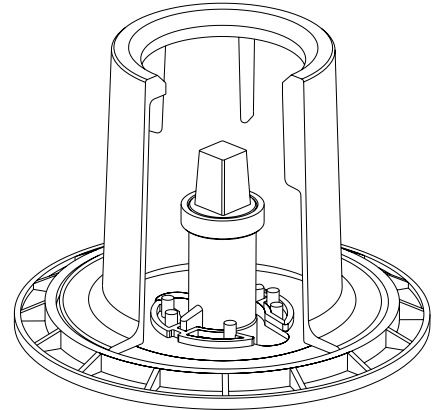

## Universal base plate No. 3481

For surface boxes according to:

- DIN 4056 (gate valves)
- DIN 4057 (service valves)

Safe fixture of HAWLE telescopic extension spindles for gate valves, Combi-T and service valves

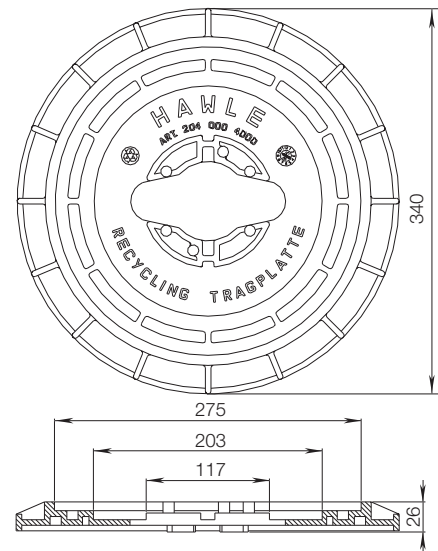

## Base plate No. 3482

For surface boxes according to:

- DIN 4055 (for below ground hydrants)

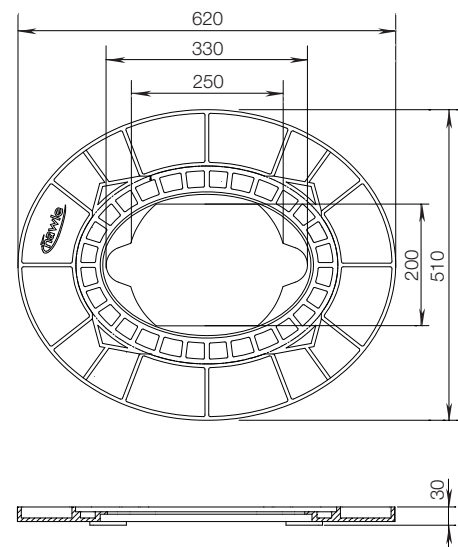

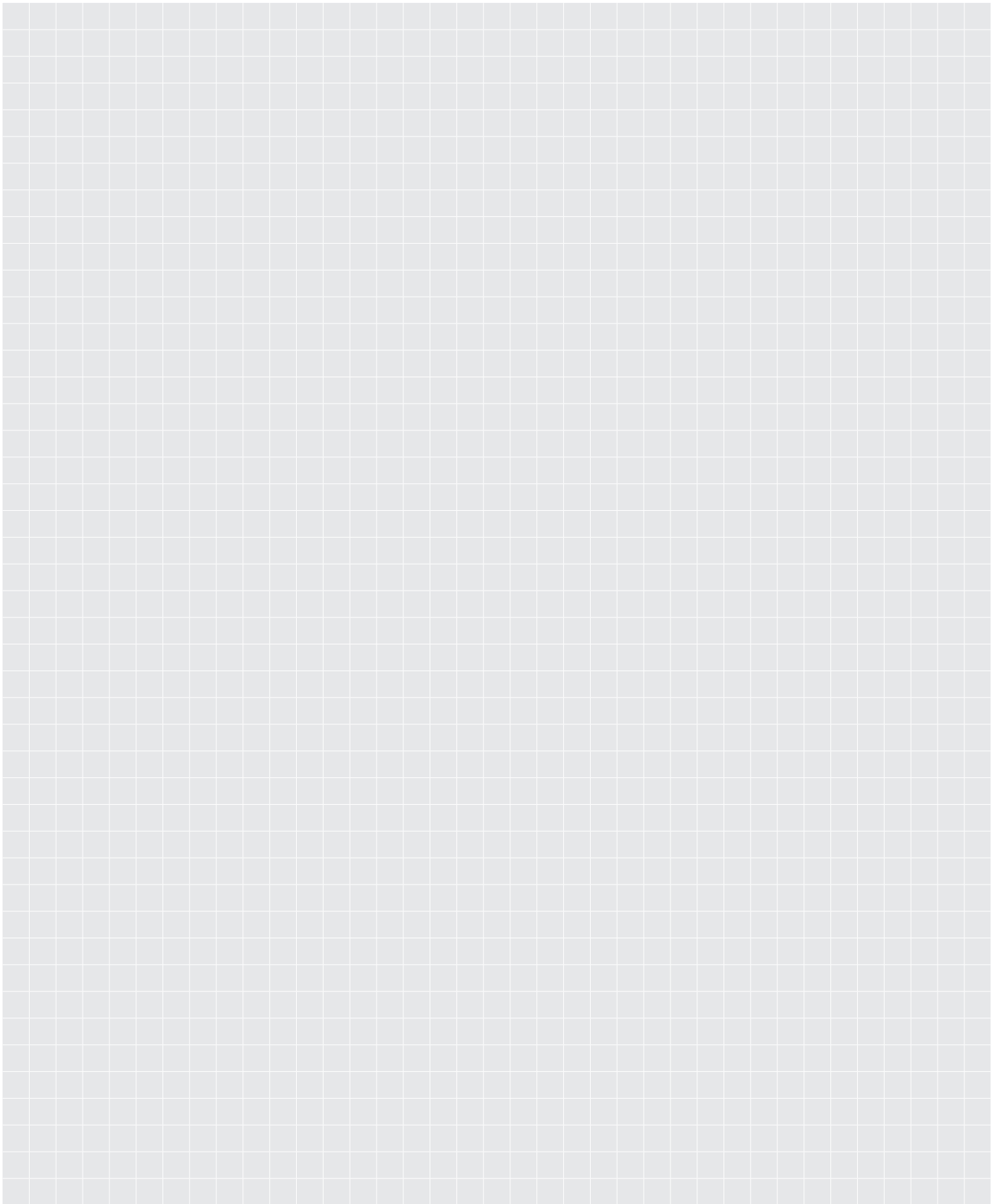

Order No.	DN	D	VK slider spindle	Weight
7800	¾" - 2"	140	10,3	0,60
	50	160	14,8	0,69
	65	190	16,3	0,90
	65-80	190	17,3	0,95
	100	240	19,3	1,50
	125 - 150	320	19,3	2,30
	200	360	24,3	2,80
	250 - 350*	486	27,3	4,80
	400**	600	32,3	21,00
	500 - 600	800	36,3	20,00

## No. 7800 Handwheel

- For service valves, gate valves and combi valves

Made of ductile iron, epoxy powder coated

\* DN 250 - 350 made of steel, epoxy powder coated handwheel made of steel 2" up to DN 200 on request!

\*\* DN 400 made of grey ductile iron

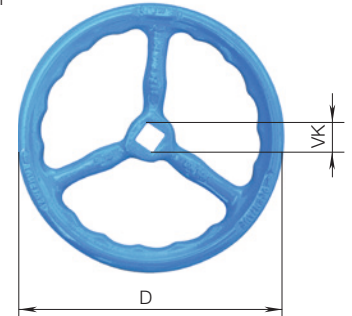

DN	No. 2157	No. 2158	No. 2156
20-40			
50			
65			
80			
100-150			
200			
250-350			
400			
500-600			

## Operating cap

- Made of aluminum, with cap and direction indicator

**No. 2157** "clockwise closing" - red

**No. 2158** "anti-clockwise closing" - blue

**No. 2156** made of galvanised ductile iron (without illustration)



DN	No. 7820 No. 7821	No. 7825 No. 7826
¾" - 2"		
50		
65		
80		
100 - 150		
200		
250 - 300		
400		
500 - 600		

## Additional extension spindle

- Material:** galvanised steel

**No. 7820** price for first meter

**No. 7821** price for each additional half meter  
please specify total length "L" on order

- Material:** stainless steel

**No. 7825** price for first meter

**No. 7826** price for each additional half meter  
please specify total length "L" on order

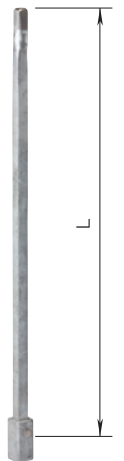

Order No.	DN	Weight
8570E2	65 - 80	1,50
	100	1,90
	125 - 150	3,20
	200	5,00

## Blanking cap

### No. 8570E2

- For combi valves in place of valve bonnet

- Made of ductile iron, epoxy powder coated without screws and hood seal



**No. 8570E2**

DN	No. 2170E2	No. 4000STE2
50		
65		
80		
100		
125		
150		
200		
250		
300		
350		
400		



## Position indicator

### No. 2170E2

- For visual display of the wedge position in **E2** valve
- Limit switch (No. 2190) for electrical signal transmission set-up is possible
- Actuation by handwheel (No. 7800)
- DN 50 to 200 for retrofitting on standard **E2** upper section



## Limit switch

### No. 2190

- For set-up on the 2170**E2** position indicator
- Body made of metal
- Operating current 230 V / 3 A
- IP 66 / IP 67 protection type
- Switching principle: slow-action contact element
- Design of the switching function: positively driven contact
- Number of openers: 1
- Number of closers: 1



## E2 valve "short"

### No. 4000STE2

- **E2** valve with flange with installed position indicator

Order No.	DN	Weight
7850	¾"-2"	0,08
	50-200	0,30



## Anti-operation cap

### No. 7850

- Only suitable for extension spindles for service valves and **E2** valve
- Use: protection against misuse (e.g.: mains disconnection valve)

Order No.	DN	Weight
7851	¾"-2"	0,20
	50-200	1,00



## T-key adapter

### No. 7851

- Suitable for anti-operation cap No. 7850



## Design features

- In standard version 400 V, 50 Hz, three phase motor, easily adjustable limit switch, dual torque switch, signal output to control flasher, thermoswitch for motor protection, handwheel for emergency use.
- Connection according to: DIN 3210 GO resp. G 1/2
- Shaft coupling: DIN 3210 E
- Enclosure of actuator: IP 68
- Enclosure of switches: IP 66

Variations from the standard version on request.

E2 valve		Actuator						
DN	MOP (PN)	Type	Max. torque	L	B	H	Weight	
50-100	16	SA 07.6	60	514	300	288	21,0	
125-200		SA 10.2	120	536	312	290	23,5	
250-400		SA 14.2	250	725	375	316	50,0	
500-600		SA 14.6	500	728	375	316	50,0	

DN	Actuator U/min	~ Closing time
50-80	16	1,0 min
100-125	16	1,5 min
150-200	16	2,0 min
250	16	2,5 min
300-400	22	2,5 min
500-600	16	4,5 min

Other closing times and versions on request!

## Design features

- E2 valve including bolts (stud bolts and nuts)  
Connector suitable for actuator No. 9920

DN	Bolt circle LK	Shaft Ød	Weight		
			4000ELE2	4700ELE2	8630E2
50	102	20	15,0	36,0	3,7
65	102	20	21,0	42,5	4,0
80	102	20	22,5	44,5	4,0
100	102	20	28,5	51,5	4,0
125	102	20	39,0	62,0	4,0
150	102	20	44,5	70,0	4,0
200	102	20	71,0	101,0	5,5
250	140	30	109,0	176,0	8,5
300	140	30	156,0	225,0	8,5
350	140	30	214,0		9,5
400	140	30	270,0		9,5
500	140	30	499,0	543,0	20,0
600	140	30	730,0	820,0	20,0

## Actuator No. 9920

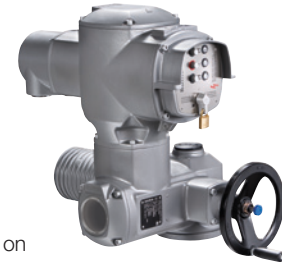
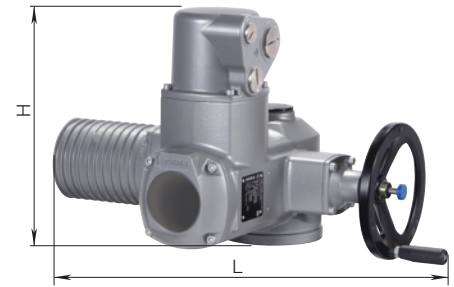

Actuator control unit  
AUMA MATIC and AUMATIC on request

The actuator should not be used with **HAWLE-E2** Elypso Valve for partial flow control.

For using the actuator with **HAWLE-E2** Elypso Valves please specify the following details on order:

1. working pressure
2. alignment of the valve
3. how often the valve is to be opened and closed within 24 hours

## E2 valve "short" with adapter for actuator No. 4000ELE2

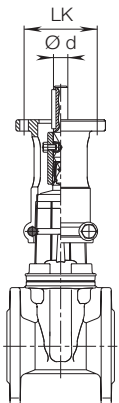

## E2 valve "long" with adapter for actuator No. 4700ELE2

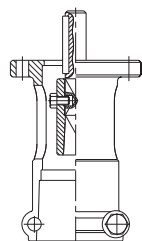

## E2 Adapter No. 8630E2

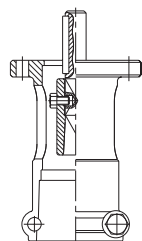

# VALVE ACCESSORIES



Bolts / L	No. 8810					No. 8830			No. 8840	
	M 16	M 20	M 24	M 27	M 30	M 16	M 20	M 16	M 20	
60										
70										
80										
90										
100										
110										
120										
130										
140										

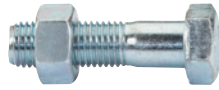

## Nut and Bolt

### No. 8810

- Electro-galvanised

### No. 8830

- Stainless steel, corrosion proofing

### No. 8840

- Stainless steel, corrosion and acid proofing

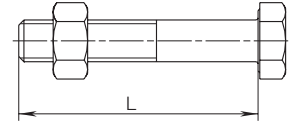

No. 8873	for M 16	
	for M 20	
No. 8874	for M 16	
	for M 20	
	for M 24	



## Washer

### No. 8873

- Stainless steel, corrosion proofing

### No. 8874

- Stainless steel, corrosion and acid proofing

	For thread	
No. 8877	M 16	
	M 20	
No. 8820	M 16	
	M 20	



## Bolt insulation

- For electrical insulation of bolts to prevention of electrolytic corrosion

### No. 8877 ISO washers

- Thickness 3 mm, made from epoxy glass

### No. 8820 pipe

- Polyester, length 1 m

## Required bolt lengths: flanged valves to flange (PN 10)

Flanged valve DN	Bolt Dimension	Bolt Quantity	Bolt length for flange no.								
			0101 0102	7101 7102 7103	0400 0800 0802 7994	5500 5530	5600	0310 0311	7602	7601	8000 8100
50	M 16	4	70	70	60	60	70	60	90	80	60
65	M 16	4	70	70	70	70	70	70	100	80	70
80	M 16	8	80	70	70	70	70	70	100	80	70
100	M 16	8	80	70	70	70	70	70	100	80	70
125	M 16	8	80	80	70	70	80	70	100	80	70
150	M 20	8	90	80	70	70	80	70	140	100	70
200	M 20	8	90	80	70		80	70	140	100	70
250	M 20	12	100	90	80		90	80	140		80
300	M 20	12	100	90	90		90	90	140		90
350	M 20	16	120								100
400	M 24	16	120		90						100
500	M 24	20	150		100						
600	M 27	20	150		120						

# HAWAK-PILLAR

For above ground operation of valve



## Design features

- For the ergonomic above-ground operation of shut-off valves buried in the ground or installed in manholes and valve chambers
- Standpipe and connecting flanges of stainless steel
- Connecting flange for fixing on support base DN 65 drilled to EN 1092

### Version with handwheel (No. 9894)

- The extended inner pipe made from galvanised steel allows quick and easy connection of the HAWAK-Pillar with the square rod of the spindle extension or extension spindle. The telescopic connection in the HAWAK-Pillar allows a generous tolerance when cutting the square rod to length
- Spindle made of stainless steel
- Spindle bearing made of POM
- Wiper ring made of elastomer
- Position indicator for monitoring of valve position
- Maintenance-free

### Version for electric actuator (No. 9895)

- Connecting flange for actuator according to EN ISO 5210 / DIN 3210

## Pillar

**No. 9894**

**No. 9895**

Not included in scope of supply!



No. 9894



No. 9895

Order No.	Version	For valves of nominal widths / DN													
		50	65	80	100	125	150	200	250	300	350	400	450	500	600
9894	Equipped with handwheel and position indicator														
9895	Model with connection for electric actuator														

When ordering please specify the valve type and the nominal width

# HAWAK-PILLAR

For above ground operation of valve



## No. 9894

- Equipped with handwheel and position indicator

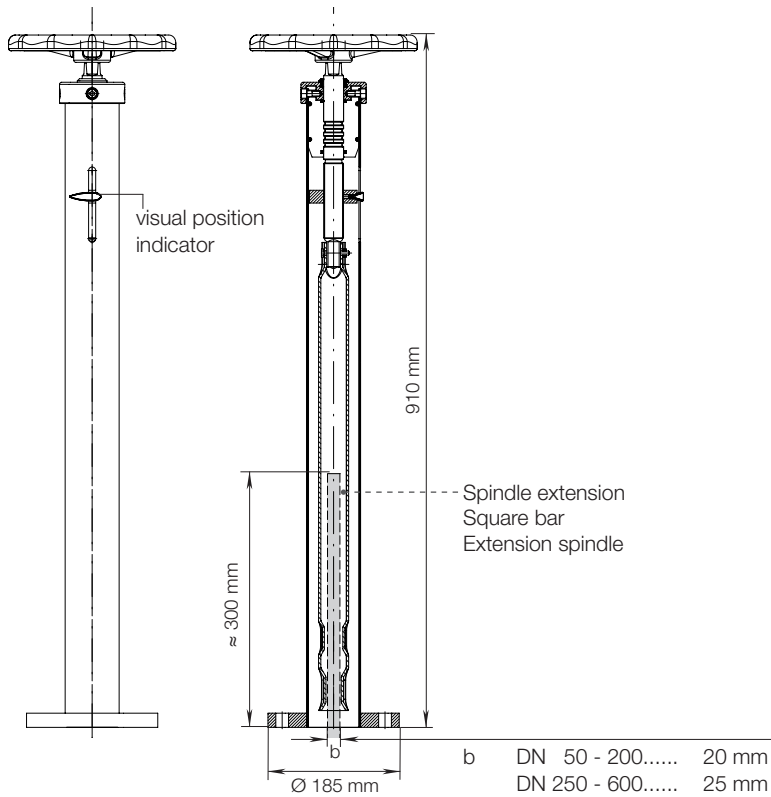

## Application example:

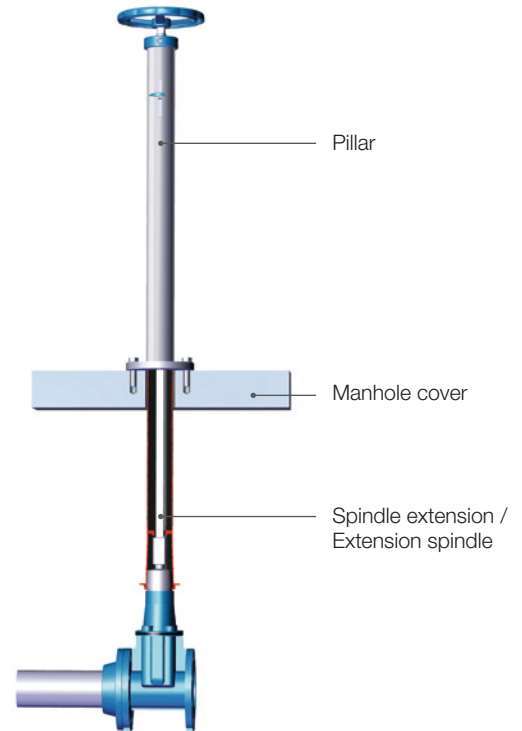

## No. 9895

- Model with motor adapter

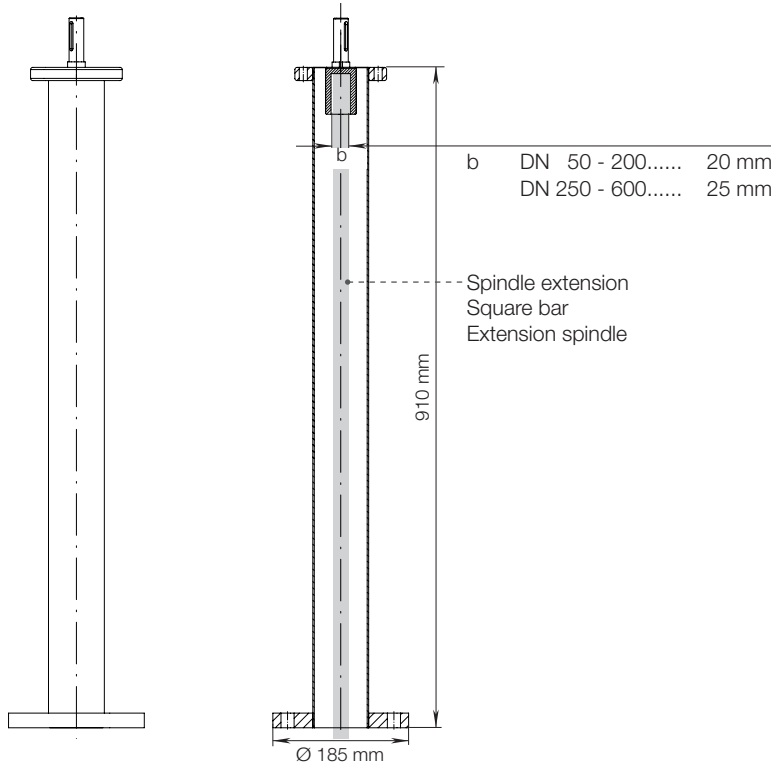

## Application example:

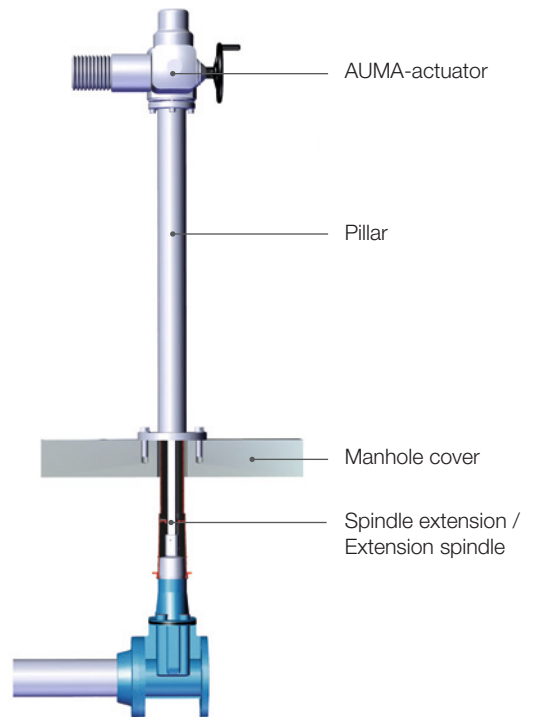

Order No.	Outlet	Weight	
5397	for A coupling	3,70	
5398	for B coupling	2,20	
5399	for C coupling	1,70	



## Theft indicator

**No. 5397**

**No. 5398**

**No. 5399**

**For HAWLE above ground hydrants**

- Effective protection against unauthorised access
- For all Hawle above ground hydrants from 1998
- For Hawle above ground hydrants before 1998 on request

Order No.	For coupling	Weight	
3453	A + B + C	0,50	



## Adapter

**No. 3453**

- Opening of hydrant solely with adapter and operating key no. 3460

### No. 5417

For hydrants made before September 1998, a "conversion kit" is needed



## Theft indicator cap

**No. 5417**

- For above ground hydrants
- Since September 1998, all HAWLE above ground hydrants have been supplied in a form that can accept theft indicator caps

### No. 5416

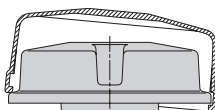

Operating nut

## Conversion kits

**No. 5416**

- For theft indicator cap
- For hydrants made before September 1988
- Standard, for all HAWLE hydrants with the standard ÖNORM-F 2010

# SUPPORT LINERS

For PE pipes



## Class SDR 11 (PE 100 | PN 16)

ØPipe ext.	ØD	ØC	ØA	F	E	B
20	15,4	10,3	19,5	42	4	16,5
25	19,8	14,3	24,5	52	5	20,9
32	25,2	19,3	31,5	62	6	26,5
40	31,6	25,3	39,5	72	7	33,2
50	39,6	32,7	49,5	82	7	41,5
63	50	42,1	62,5	91	8	52,2

## Support liners made of POM for PE pipes

No. 6031



## Class SDR 17,6 (PE 100 | PN 10)

ØPipe ext.	ØD	ØC	ØA	F	E	B
20	15,4	10,3	19,5	42	4	16,5
25	20,4	15,2	24,5	52	5	21,5
32	27,4	22,2	31,5	67	6	28,5
40	34,8	28,5	39,5	84	7	36
50	43,4	36,5	49,5	82	7	44,9
63	54,8	46,9	62,5	92	8	56,6

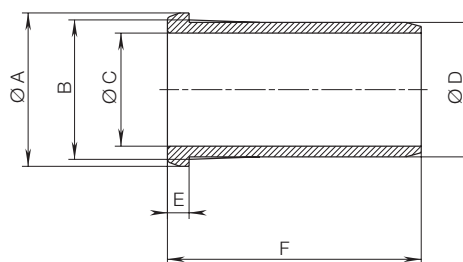

ØPipe ext.	L	Weight
63	170	0,10
75	170	0,25
90	170	0,33
110	170	0,39
125	170	0,48
140	170	0,55
160	200	0,67
180	220	0,86
200	220	1,50
225	220	1,62
250	220	1,85
280	220	2,15
315	220	2,55

## Support liner made of stainless steel for PE pipes

No. 6035

Class SDR 17,6 (PE 100 | PN 10)

No. 6036

Class SDR 11 (PE 100 | PN 16)

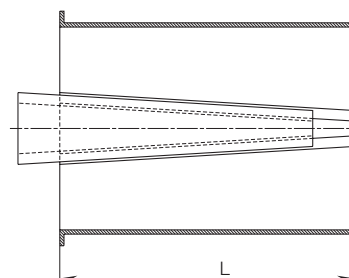

Order No.	DN	Face-to-face length L	Weight
<b>8653</b>	50	300	0,9
	65		1,1
	80		1,3
	100		1,5
	125		1,9
	150		2,4
	200		3,2
	250		3,9
	300		4,8
	350		5,7
	400	6,7	

other dimensions on request!

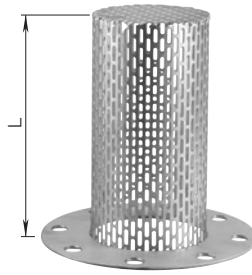

## Suction strainer No. 8653

- Made of stainless steel
- Flange hole according to EN 1092-1 | PN 10

DN	b		Weight	
	3470	3390	3470	3390
25		4		0,01
32		4		0,02
40		4		0,03
50	3	4	0,02	0,04
65	3	4	0,03	0,06
80	3	4	0,04	0,07
100	3	5	0,04	0,07
125	3	5	0,05	0,12
150	4	5	0,06	0,13
200	4	6	0,10	0,18
250	4	6	0,13	0,23
300	4	6	0,17	0,60
350		7		0,70
400		7		0,77
500		7		1,00
600		7		1,11



## Flat gasket No. 3470

- With fabric liner, PN 10
- Made of elastomer



## Flat gasket No. 3390

- Dimensionally stable reinforced steel, thus simpler to install
- Made of elastomer
- Standard version PN 10, PN 16 or PN 25 on request



No. 3470

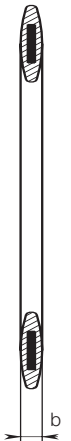

No. 3390

DN	No. 7540	No. 7560
80		
100		
125		
300		



## Enlarging sleeve

- For flange adaptors
- To increase pipe outside diameter to fit flange adapter

**No. 7540 sleeve gauge 2** (60 wide)

**No. 7560 sleeve gauge 3** (80 wide)

Please specify pipe material and diameter

## Design features

- For an easy installation
- Made of pure silicon (with a special solvent)
- Suitable for potable water
- Content: 400 ml
- **Attention:** observe the safety-instruction label on the can

## Mounting spray For PE and PVC pipes

No. 3443



## Design features

- Suitable for valves, spindles and O-rings
- Content: 90 g

## Fitting grease

For potable water valves

No. 3444



## Design features

- The dimension and type of spacer is determined by the diameter of the medium carrier pipe
- The pipeline spacer height is dependent on the inside diameter of the protective tube
- Fits easy onto pipe
- Elements portioned per ring
- No additional tools necessary
- High tolerance, withstands 2000 kg/ring
- Suitable for water, gas, sewage

## Pipeline spacer

(Anti-friction distance clamps)

No. 9941

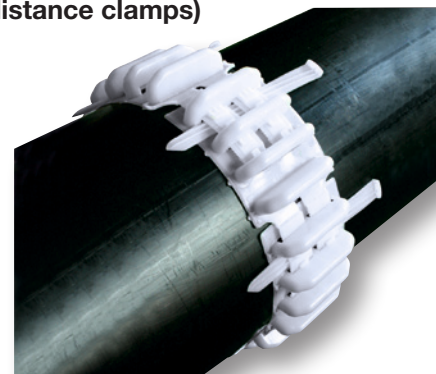

DN	External Ø medium pipe	Base height		
		25	41	60
80	76-115			
100	103-131			
125	117-172			
150	155-195			
200	207-260			
250	258-326			
250	236-312			
300				
350	295-390			
400	353-468			
450	413-546			
500	472-624			
600	501-702			

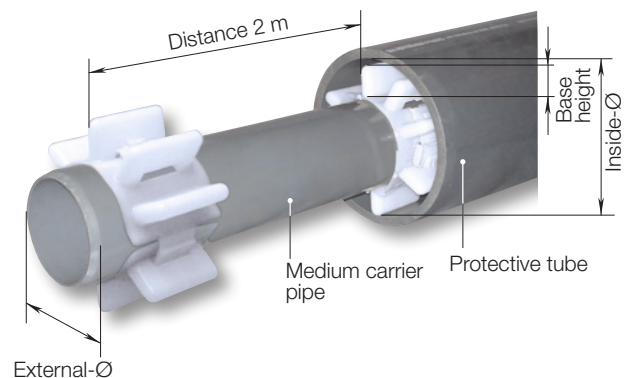



## Design features

- Made of plastic, impact-resistant, weather-proof, with interchangeable characters

Order No.	Dimensions	Version
<b>0850W</b>	200 x 140	blank*
<b>0854</b>	200 x 140	
<b>0860W</b>	100 x 140	blank*
<b>0864</b>	100 x 140	
<b>0870W</b>	200 x 250	blank*
<b>0874</b>	200 x 250	
<b>0912</b>	100 x 140	
	140 x 200	
<b>0920</b>	1500	

\* Suitable numeric or character fields are to be ordered as needed!

A = 10 mm

B = 25 mm

C = 40 mm

No. 0850W

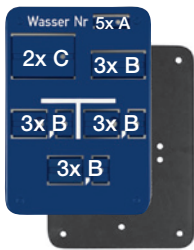

No. 0854

No. 0860W



No. 0864

No. 0870W

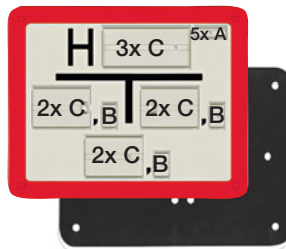

No. 0874

No. 0912



No. 0914



No. 0920



## Design features

- When ordering indicator plates, please specify respective numbers, letters and colour requested!

for indicator plates No.	Order No.	Numbers and letters 1-space					Blank 1-space					Blank 5-space	
		0880W	0881H	0881W	0882H	0882W	0890W	0891H	0891W	0892H	0892W	0900H	0900W
	Size	10	25	25	40	40	10	25	25	40	40	10	10
0850W													
0860W													
0870W													

## Numbers and letters

### Inserts for indicator plates

## Design features

- For clearly displayed storage of numbers and letters for indicator plates  
Please specify the colour requested!  
„blue”- **W**ater  
„white”- **H**ydrants

## Alu box for inserts

- No. 0910 empty
- No. 0911 filled (for app. 100 plates)



## Design features

- Non-decaying locating and warning tape with the message „BEWARE WATER PIPE“
- **No. 0820:** without metal insert
- **No. 0830:** with metal insert - for laying on non-metallic lines

**No. 0820**

Roller to 250 meters

## Warning tape

**No. 0820**

**No. 0830**

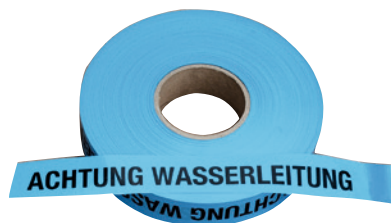

## Design features

- With one external thread outlet EN 10226-1
- Made of POM
- Every push-fit end can be modified to a external thread outlet

Order No.	DN	Thread	L	Weight
6630	¾"	¾"	92	0,05
	1"	1"	105	0,10
	1¼"	1¼"	123	0,13
	1½"	1½"	144	0,18
	2"	2"	160	0,28
6631	1"	1½"	117	0,07
	1"	2"	126	0,12

## Push fit swivel converter

**No. 6630** equal

**No. 6631** special dimensions

