

EXTENSION SPINDLE

Rigid or telescopic



Design features

- One extension spindle for several dimensions
- Protective cover with integrated locking mechanism
- No additional fixing (bolt/pin) necessary
- DN 50 to 200

Order No.	Version	Pipe cover (RD)	Dimension/DN		
			50/65/80/100	125/150	200
9000E2	rigid	1,00 m			
		1,25 m			
		1,50 m			
		2,00 m			
		2,50 m			
9500E2	telescopic	1,30 - 1,80 m			
		1,35 - 1,80 m			
		2,00 - 2,50 m			
		2,50 - 3,50 m			

Suitable accessories

- **Extender for rigid spindle**
Order no. 7830 price for first meter
Order no. 7831 price for each additional half meter
- Please specify dimensions and length when ordering

Design features

- Attachment of the extension spindle to the valve spindle takes place with a stainless steel splint
- DN 250 to 600

Order No.	Version	Pipe cover (RD)	Dimension/DN					
			250	300	350	400-500*	500	600
9000E2	rigid	1,00 m						
		1,25 m						
		1,50 m						
		1,90 m						
		2,00 m						
		2,40 m						
		2,50 m						
9500E2	telescopic	1,40 - 1,80 m						
		1,50 - 1,80 m						
		1,90 - 2,20 m						
		2,00 - 2,30 m						
		2,00 - 2,50 m						
		2,50 - 3,50 m						

* Body DN 400, with flange connection DN 450 or 500

For E2 valves and E2 Combi valves DN 50-200

No. 9000E2

Rigid

No. 9500E2

Telescopic

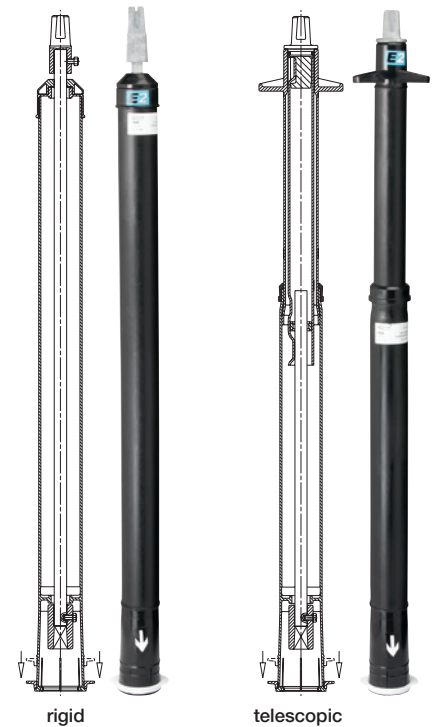

For E2 valve DN 250-600

No. 9000E2

Rigid

No. 9500E2

Telescopic



EXTENSION SPINDLES

Rigid or telescopic



No. 9000E2 / 9500E2

All extension spindles (rigid or telescopic) of all types and dimensions are protected against dirt and surface water.

The telescopic extension spindle can be progressively adjusted to ground level. This is done by pushing or pulling the tube and the spindle shaft.

The telescopic effect protects the pipe and fitting from surface impact.

Rigid version of the extension spindle can be shortened on site by removing the outer cover cap, cutting both the spindle and outer cover the required amount then re-installing the outer cover cap.

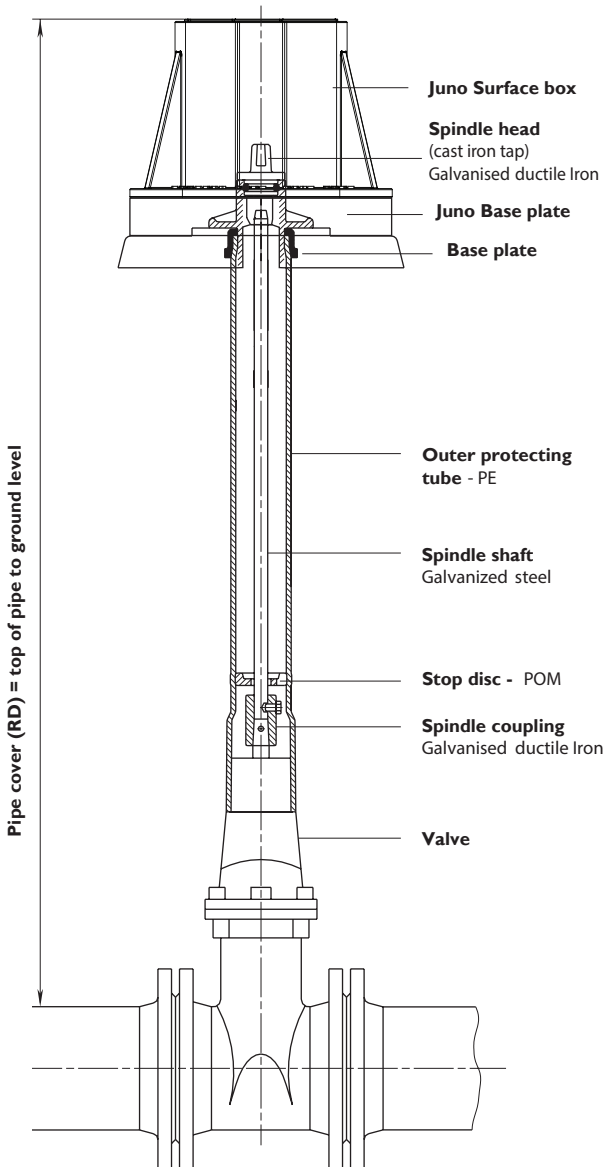
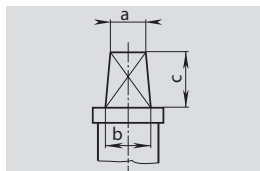

Illustration: 9000E2 DN 50-600

Spindle head | square



For service valves	a 13 mm
	b 15 mm
	c 24 mm
For valves and combi valves	a 27 mm
	b 32 mm
	c 48 mm

9000E2	Weights extension spindles, rigid – DN								
Pipe cover (RD)	50/65/80/100	125/150	200	250	300	350	400-500	500	600
1,00 m	3,50	2,80	2,70	3,10	3,00				
1,25 m	4,50	3,70	3,50	4,70	4,30	4,20	3,55		
1,50 m	5,50	4,80	4,50	6,00	5,80	5,40	5,00		
1,90 m								7,40	
2,00 m	7,45	6,60	6,50	9,00	8,70	8,45	7,80		7,40
2,40 m								7,40	
2,50 m	9,40	8,60	8,50	12,20	12,00				7,40

9500E2	Weights extension spindles, telescopic – DN								
Pipe cover (RD)	50/65/80/100	125/150	200	250	300	350	400-500*	500	600
1,30 - 1,80 m	6,60	6,25							
1,35 - 1,80 m			6,10						
1,40 - 1,80 m				7,30					
1,50 - 1,80 m					6,90	6,70	6,30		
1,90 - 2,20 m								8,80	
2,00 - 2,30 m									8,80
2,00 - 2,50 m	9,50	8,90	8,60	11,00	10,50	10,20	9,70		
2,50 - 3,50 m	12,80	12,00	11,90	15,30	14,90	14,50	14,20		
2,60 - 3,50 m								14,50	14,00

* Body DN 400, with flange connection DN 450 or 500

Assembly instructions

Fig.: Assembly E2 extension spindle DN 50-200

