

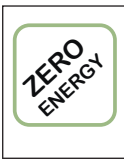

100:NE4



DESCRIPTION

A single piece moulded retro-reflective bollard with integral flexing feature, in either single or dual aspect. Recessed graphics and a flex point positioned to avoid panel creasing helps minimise damage during an impact.

Independently tested and meets the requirements of BS EN 12767:2007 100:NE4



BS8442:2006 clause 14 RSRB

CONSTRUCTION

Body

Single piece, rotationally moulded using UV stabilised linear low density polyethylene with easy clean surface treatment.

Graphics

A 300mm diameter aspect in microprismatic retro-reflective material. All reflective panels meet the requirements of BS EN8408:2005.

Mounting

The multi fixing system allows direct mounting to a flat surface, to Simmonsins CABEX unit, to a NAL Socket and to most other manufacturer's bases.

LIGHTING EQUIPMENT

N/A - Reflective only.

OPTIONS

Available in single or dual aspect.
Body available in white or black.
Sign face options, listed below.

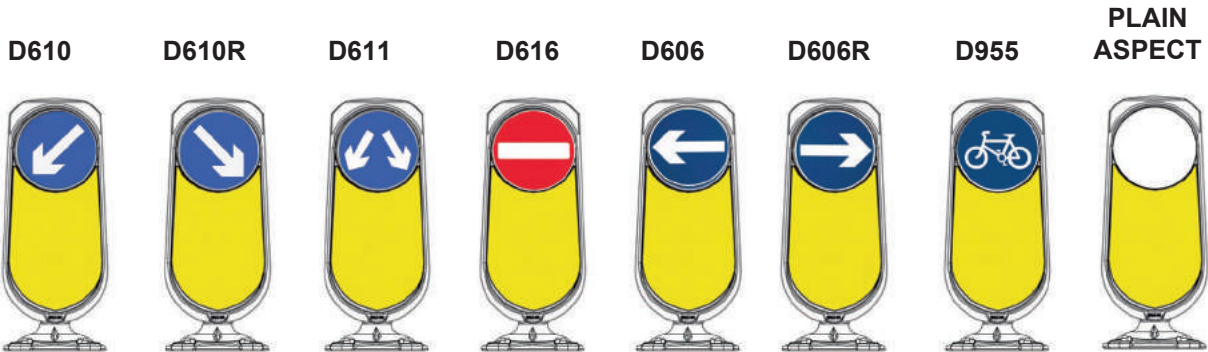

* Dft approval is required for certain applications.

Further advice on the WEEBOL FLEX including specific installation requirements is available from IPL group. Measurements and weights are approximate. The designs are the property of Innovative Products Ltd (IPL group) and may not be reproduced without express permission. Innovative Products reserve the right to amend specifications or to withdraw models without prior notice. © November 2016.



DIMENSIONS

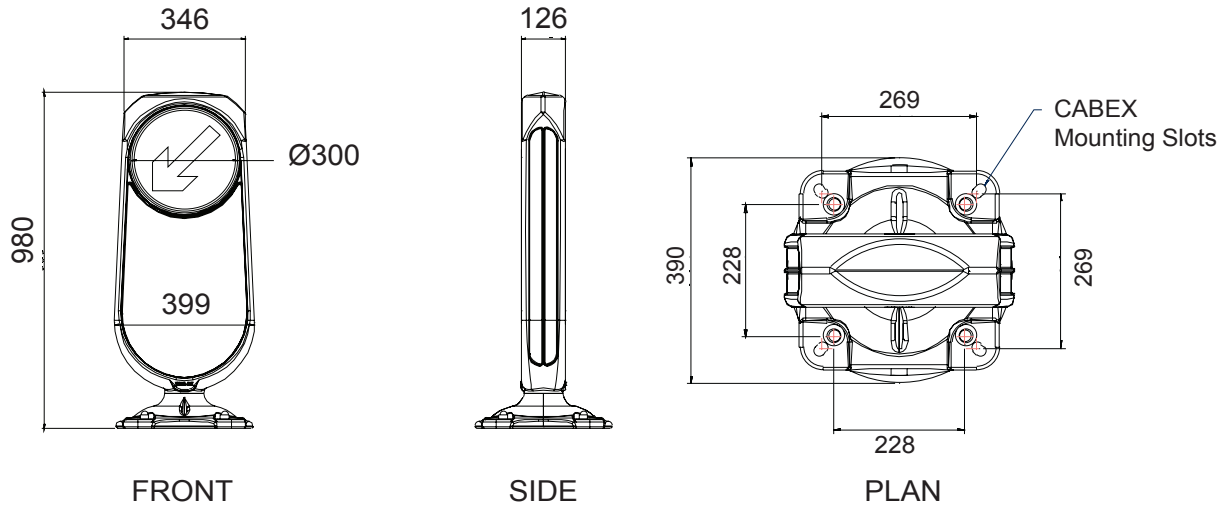

FIXING METHODS

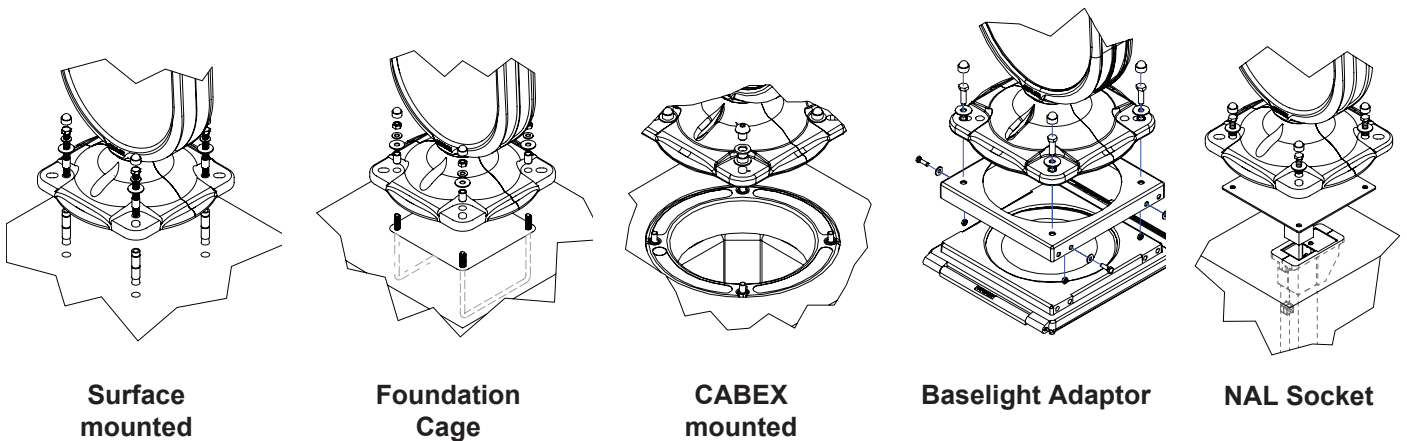

PACKAGING DETAILS

| Product | Weight | Packing | Dimensions | Pack Quantity |
|---------------------|--------|-----------------------------|-------------------|---------------|
| Weebol Flex Singles | 8kg | Heavy duty polyethylene bag | 112 x 40 x 40 cm | 1 |
| Weebol Flex Pallet | 138kg | Shrink wrapped on pallet | 120 x 80 x 175 cm | 16 |

Further advice on the WEEBOL FLEX including specific installation requirements is available from IPL group. Measurements and weights are approximate. The designs are the property of Innovative Products Ltd (IPL group) and may not be reproduced without express permission. Innovative Products reserve the right to amend specifications or to withdraw models without prior notice. © November 2016.

