

## DESCRIPTION

Following on from the successful Global baselight, the Global Plus is a compact design which utilises a separate gear housing and anchor system. The Global Plus is available as a free-standing unit complete with anchor bars or fully ducted when coupled with the Cabex foundation system. The Global Plus offers future-proof low maintenance with the vulnerable parts of the base above ground level being quickly replaceable without disturbing the foundation or electrical connections.

## CONSTRUCTION

### Hinge Frame/Platform

Die cast LM6-M marine grade alloy. Provides industry standard bollard fixing points.

### Gear Enclosure

Injection moulded UV stabilised glass coupled polypropylene. 2 no. IP68 nylon variable cable glands fitted as standard (one blanked), accepting a cable diameter between 8mm and 17mm.

### Hinge System

7.5mm solid stainless steel (316) rod, running in cast-in stainless steel (304) tubular bushes.

### Lock

M8 stainless steel (304) Tri-head penetrating cast-in stainless steel (A4) M8 threaded fixing on base casing.

### Fuse Board

250mm x 160mm x 12.5mm thick non-hygroscopic plywood bolt fixed to base bottom.

### Lens and Seal

Domed 5mm thick, UV stabilised, injection moulded polycarbonate incorporating a UV stabilised, high performance, silicon rubber seal. A compression control feature protects against over compression for a maintainable IP67 rating.

### Anchor System

Free-standing - Pre-fitted with 12mm stainless steel (316) anchor bars, nuts and washers. Cabex - Transit bolts in lieu of anchor bars with glands positioned for bottom cable entry. Cabex duct must be ordered separately.

### Cabex Body

Rotationally moulded UV stabilised black polyethylene, 6mm thick (nom.) Stackable, rotatable design allows multiple units to be used together for increased depth and differing duct entry paths.

### Cabex Duct Entry

4 x knife/knock-outs to accept 50mm or 100mm diameter conduit.

## PACKAGING

Product	Weight	Packing	Dimensions	Pack Quantity
Global Plus	9.6 kg	Carton	47 x 42 x 24 cm	1
Cabex	6.1 kg	Heavy poly bag	50 x 50 x 50 cm	1

Further advice on the GLOBAL PLUS & CABEX including specific installation requirements is available from IPL group. Measurements and weights are approximate. The designs are the property of Innovative Products Ltd (IPL group) and may not be reproduced without express permission. Innovative Products reserve the right to amend specifications or to withdraw models without prior notice. © November 2016.



### OPTIONS

#### Safety

Double-pole isolator - isolates power to gear tray as lens is removed.

Cover Plate - pre-galvanised cover plate to cap the Cabex during installation prior to fitting the baselight.

#### Control

Infrared photo-electric cell - various manufacturers.

Remote monitoring module - various manufacturers.

#### Uplighter

Available with a gear tray configured as an uplighter.

### LIGHTING EQUIPMENT

LED*				
Voltage	240V AC		24V AC	
	10 x 1W*	3 x 1W	10 x 1W*	3 x 1W
Power	14	4	19	7
Warranty	2	2	2	2

LED and optical array mounted on a thermally engineered removable gear tray.

Single IP67 electronic driver with  $\geq 0.85$  power factor correction. Note: the 10 x 1 W LED has two drivers.

All components are fitted to a 0.5mm thick stainless steel (304) gear tray and have removable stainless steel fixings for easy replacement.

Please note: Improvements in LED technology may result in a change to this information.

\*Available configured as an uplighter.

### RELATED PRODUCTS



SIMBOL



CONTOUR



WEEBOL PLUS

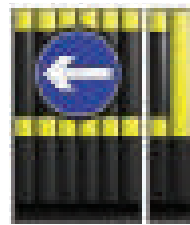

INSIGHT  
(GLOBAL PLUS UPLIGHTER)



GLOBAL

Further advice on the GLOBAL PLUS & CABEX including specific installation requirements is available from IPL group. Measurements and weights are approximate. The designs are the property of Innovative Products Ltd (IPL group) and may not be reproduced without express permission. Innovative Products reserve the right to amend specifications or to withdraw models without prior notice. © November 2016.



**DIMENSIONS**

**GLOBAL PLUS FREE-STANDING**



**GLOBAL PLUS WITH CABEX**

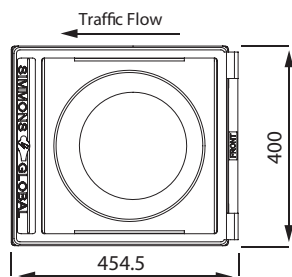
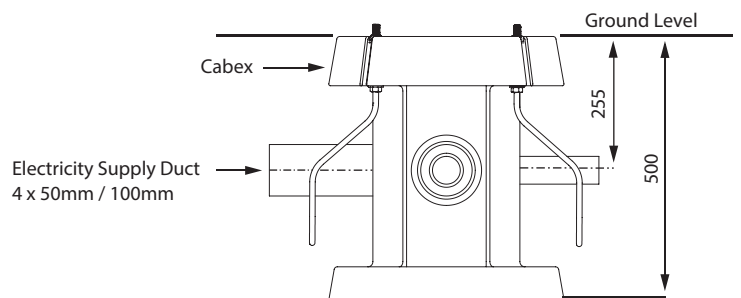
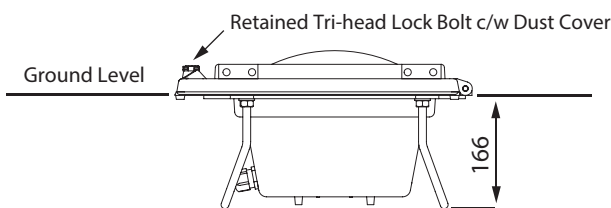
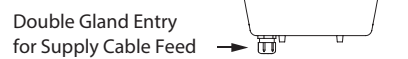
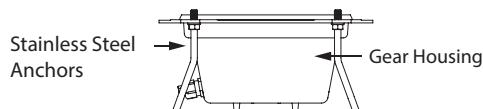
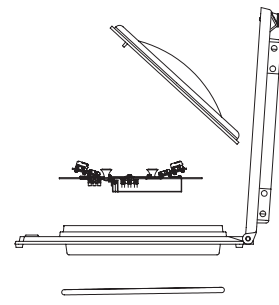
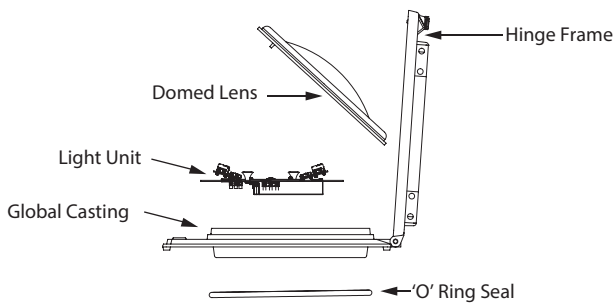

Further advice on the GLOBAL PLUS & CABEX including specific installation requirements is available from IPL group. Measurements and weights are approximate. The designs are the property of Innovative Products Ltd (IPL group) and may not be reproduced without express permission. Innovative Products reserve the right to amend specifications or to withdraw models without prior notice. © November 2016.

